

HCP 3.00 Railcar Vibrator

The NAVCO[®] Hopper Car Portable (HCP) 3.00 pneumatic piston railcar vibrator is designed to provide reliable and effective performance while operating in severe environments. The size and operating characteristics of the HCP 3.00 make it ideal for handling by personnel in lighter duty railcar bulk material unloading applications.

Key Features

Free Ride Design:

The NAVCO HCP Railcar Vibrator is constructed specifically for use in the universal mounting brackets found on railcars. The Free Ride design allows the HCP to fit loosely in the top of the bracket. By fitting loosely in the bracket, the HCP is given space to move back and forth freely. This freedom of movement allows the HCP to utilize its full mass to create a hammer like impact on the railcar on both strokes of the piston. These impacts promote flow for unloading railcars by eliminating rat holing and bridging. The free ride design keeps the HCP at the top of bracket stopping it from wedging itself in the bracket and becoming difficult to remove. This eliminates the need to use sledge hammers or air flow reversal to remove the HCP.

PTFE Internal Coating:

HCP Railcar Vibrators are manufactured with an internal low-friction PTFE coating. Because railcar vibrators often operate in harsh environments, the special coating is standard on every HCP Railcar Vibrator. This ensures an extended operational life with low maintenance requirements.

Rugged Mounting Head:

The HCP mounting head features a rugged, hardened steel construction and fits universal mounting brackets found on railcars.

Lifting Handle:

The handle's design allows for the unit to be easily inserted by the operator, providing maximum user comfort and minimizing fatigue.



Low Frequency Operation:

NAVCO HCP Railcar Vibrators run at low-frequency, ensuring the integrity of the railcar and compatibility with railcar manufacturer recommendations.

CONTACT US TODAY AT

E. SALES@NAVCO.US W. NAVCO.US A. 11929 Brittmoore Park Dr.
P. 832.467.3636 F. 832.467.3800 Houston, TX 77041

HCP 3.00

Operating Characteristics

Frequency

@ 50 PSI 1800 vpm

Air Consumption

@ 50 PSI 15.0 SCFM

Weight

72 lbs

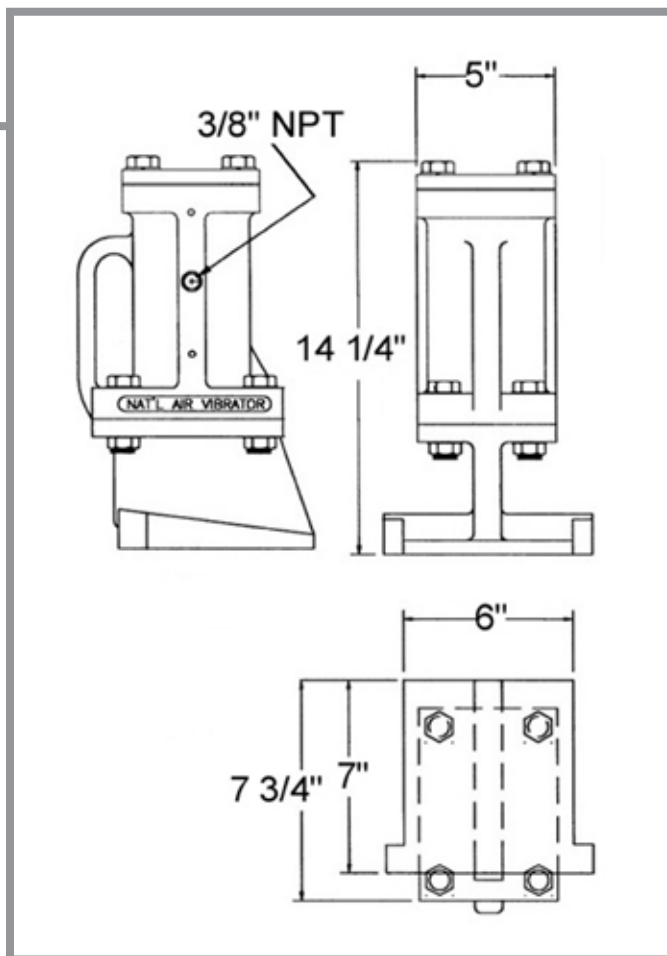

Sizing and Installation

The HCP 3.00 is designed to fit loosely in the railcar's universal mounting bracket upon installation. The unit should be allowed to move freely in the bracket during operation.

A well designed air supply line system is recommended to allow clean, dry, and lubricated air to reach the vibrator. Care should be taken to keep air supply lines free from contaminants. Recommended operating air pressure is 20 to 60 PSI (at the vibrator).

Automatic on/off cycling is suggested to optimize the unloading process. Additional benefits of cycling include extended vibrator life and reduced utility consumption.

Any further questions concerning vibrator installation and/or application should be directed to NAVCO.

Accessories and Options

All airline accessories required for the complete installation of HCP units are available through NAVCO.

To ensure proper application and operation of the HCP Railcar Vibrator, a complete line of system accessories are available.

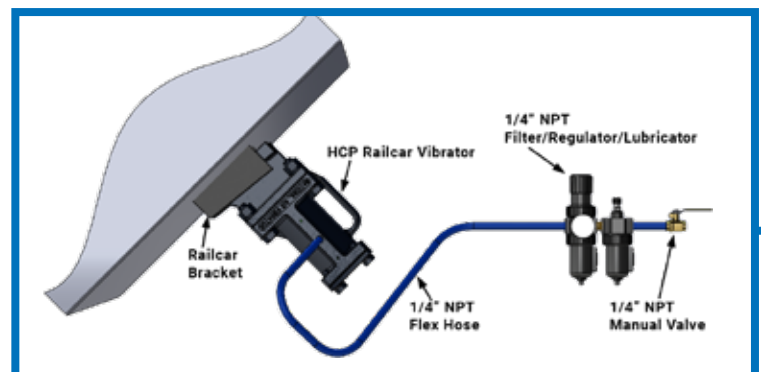

HCP Railcar Vibrator Sizes

NAVCO HCP units are available in the following sizes: 2.00, 3.00, 3.L0 and 4.00. Contact your local representative or NAVCO directly for assistance in selecting the appropriate vibrator for your application.

CONTACT US TODAY AT

E. SALES@NAVCO.US W. NAVCO.US

A. 11929 Brittmoore Park Dr.
Houston, TX 77041

P. 832.467.3636

F. 832.467.3800