

The Chem-Tech Series 100 is the standard by which all other dosing pumps are judged, Chem-Tech Series 100/150 pumps with motorized-diaphragm technology deliver dependable performance and extended longevity. The Series 100/150 provides quiet, consistent metering over long periods of time in a compact form.

A tried-and-true electric motor transfers power via a sealed gearbox and eccentric cam for smooth, **reliable** dosing.

Simple, adjustable system with knob and locking lever provide **easy** flow rate control and turndown.

The compact, injection-molded housing and clear pump head offer both **affordability** and chemical resistance.

The industrial grade, low-stress diaphragm provides **long life**, even in harsh conditions and continuous duty cycles.

**Series 100 Models** - The preferred metering pump for water conditioning professionals around the world. Perfect for applications where economical, consistent performance is required. Capable of a wide range of flows, from less than 3 USGPD (0.47 lph) up to 30 USGPD (4.72 lph) and pressures up to 100 PSIG (7 BAR).

**Series 150 Models** - Built upon the same solid platform as the 100 Models, these units are capable of higher flow rates. With a range offering up to 100 USGPD (15.76 lph), the Series 150 can meet the demands of larger applications. Maximum pressure is 60 PSIG (4.2 BAR).

## Features

- Guided Quad Check Valve System.
- Bleed Valve Assembly Standard.
- Feed Rate Control.
- Duplex Models. Both Series are configurable for dosing two chemicals at different rates.

## Controls



### Feed Rate Control

- Adjustable Feed Rate.

## Operating Benefits

- Reliable metering performance.
- Sealed gear train.
- Easy tube change-out.
- Self priming.
- Chemical resistant materials.
- Simple installation.



## Aftermarket

- KOPkits
- Gauges
- Dampeners
- Pressure Relief Valves
- Tanks
- Pre-Engineered Systems
- Process Controllers (PULSAblue, MicroVision)



Standard Agency Listings			
Model	ETL	ETLsan	CE
All 60Hz	X	X	
100-150 50Hz			X
200 50Hz			
Contact factory for alternate listings			



## Specifications and Model Selection

MODELS:	MODELS:
<b>Series 100</b>	<b>Series 100D Duplex Pump</b>
X003 = 3 gpd (0.47 lph) max pres.: 100 PSI (7 BAR)	144 = 4.0 gpd (0.63 lph) / 4.0 gpd (0.63 lph) max pres.: 50 PSI (3.5 BAR)
X007 = 7 gpd (1.00 lph) max pres.: 100 PSI (7 BAR)	145 = 5.0 gpd (0.79 lph) / 4.0 gpd (0.63 lph) max pres.: 50 PSI (3.5 BAR)
X015 = 15 gpd (2.34 lph) max pres.: 100 PSI (7 BAR)	155 = 5.0 gpd (0.79 lph) / 5.0 gpd (0.79 lph) max pres.: 50 PSI (3.5 BAR)
X024 = 24 gpd (3.78 lph) max pres.: 100 PSI (7 BAR)	244 = 6.5 gpd (1.03 lph) / 6.5 gpd (1.03 lph) max pres.: 75 PSI (5.25 BAR)
X030 = 30 gpd (4.72 lph) max pres.: 100 PSI (7 BAR)	245 = 7.5 gpd (1.18 lph) / 6.5 gpd (1.03 lph) max pres.: 75 PSI (5.25 BAR)
<b>Series 150</b>	255 = 7.5 gpd (1.18 lph) / 7.5 gpd (1.18 lph) max pres.: 75 PSI (5.25 BAR)
X068 = 68 gpd (10.72 lph) max pres.: 60 PSI (4 BAR)	264 = 12.0 gpd (1.89 lph) / 8.0 gpd (1.26 lph) max pres.: 60 PSI (4.2 BAR)
X100 = 100 gpd (15.76 lph) max pres.: 60 PSI (4 BAR)	265 = 12.0 gpd (1.89 lph) / 9.0 gpd (1.43 lph) max pres.: 60 PSI (4.2 BAR)
	344 = 14.0 gpd (2.21 lph) / 14.0 gpd (2.21 lph) max pres.: 75 PSI (5.25 BAR)
	345 = 18.0 gpd (2.84 lph) / 14.0 gpd (2.21 lph) max pres.: 75 PSI (5.25 BAR)
	355 = 18.0 gpd (2.84 lph) / 18.0 gpd (2.84 lph) max pres.: 75 PSI (5.25 BAR)
	364 = 25.0 gpd (3.94 lph) / 15.0 gpd (2.37 lph) max pres.: 60 PSI (4.2 BAR)
	365 = 25.0 gpd (3.94 lph) / 19.0 gpd (3.0 lph) max pres.: 60 PSI (4.2 BAR)
	444 = 30.0 gpd (4.72 lph) / 30.0 gpd (4.72 lph) max pres.: 75 PSI (5.25 BAR)
	445 = 30.0 gpd (4.72 lph) / 33.0 gpd (5.20 lph) max pres.: 75 PSI (5.25 BAR)
	<b>Series 150D Duplex Pump</b>
	455 = 33.0 gpd (5.20 lph) / 33.0 gpd (5.20 lph) max pres.: 75 PSI (5.25 BAR)
	464 = 69.0 gpd (10.88 lph) / 32.0 gpd (5.05 lph) max pres.: 60 PSI (4.2 BAR)
	465 = 69.0 gpd (10.88 lph) / 24.0 gpd (3.79 lph) max pres.: 60 PSI (4.2 BAR)
	466 = 69.0 gpd (10.88 lph) / 69.0 gpd (10.88 lph) max pres.: 60 PSI (4.2 BAR)

## Engineering Data

<b>Pump Head Materials Available:</b>	Clear PVC PVC PP 316SS CSPE Viton PTFE-faced CSPE
<b>Diaphragm:</b>	CSPE Viton PTFE-faced CSPE
<b>Check Valves Materials Available:</b>	PTFE CSPE Viton
<b>Seats/O-Rings:</b>	PTFE CSPE Viton
<b>Balls:</b>	Ceramic PTFE 316 SS GFPPPL PVC PVDF
<b>Fittings Materials Available:</b>	Same as fitting and check valve selected, except 316SS
<b>Bleed Valve:</b>	Same as fitting and check valve selected
<b>Injection Valve &amp; Foot Valve Assy:</b>	Clear PVC White PE Black PE
<b>Tubing:</b>	

Important: Material Code - GFPPPL=Glass-filled Polypropylene, PVC=Polyvinyl Chloride, PE=Polyethylene, CSPE=Generic formulation of Hypalon, a registered trademark of E.I. DuPont Company. Viton is a registered trademark of E.I. DuPont Company. PVC wetted end recommended for sodium hypochlorite.

## Dimensions All dimensions expressed as inches (mm)

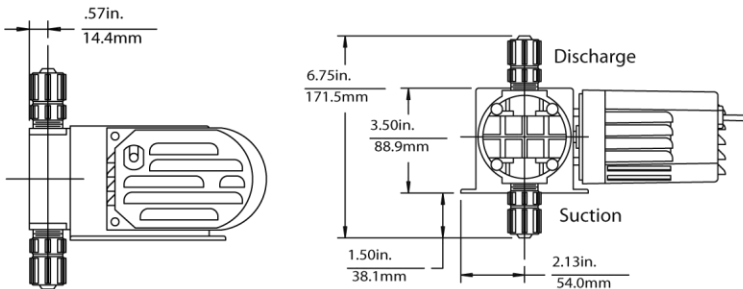

## Engineering Data

<b>Viscosity Max CPS:</b>	300 CPS
<b>Power Input:</b>	115 VAC/60 HZ, 230 VAC/50 HZ 230 VAC/60 HZ
<b>Temperature Limitations:</b>	125°F / 51°C max.
<b>Shipping Weight:</b>	8 lbs. / 3.63kg.

Specifications subject to change without notice.

## Integrated Tank Systems



### Integrated Tank Systems

Pulsafeeder's ITS System is a completely integrated tank system constructed of high density UV resistant polyethylene (PE) with a 15 gallon capacity. This tank system is translucent with 5 gallon increments and the tank's low level indicator allows visual monitoring of chemicals without opening the tank. The tight fitting child proof lid keeps the chemical free of contaminants and protects the surrounding area from chemical fumes.

The ITS System also allows for easy access to the liquid end and control panel of the mounted pump.

A system consists of a chemical tank with lid and bulkhead fittings: a liquid level indicator float assemble and feeder mounting hardware.

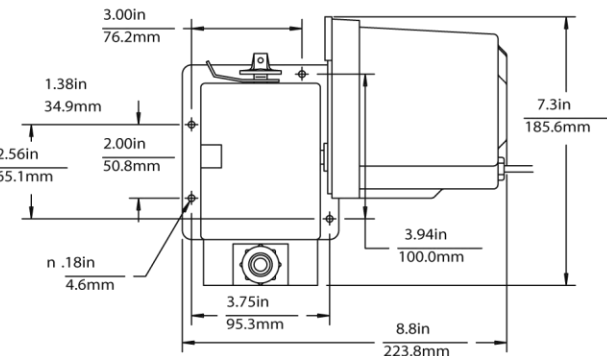

[pulsafeeder.com](http://pulsafeeder.com)



27101 Airport Rd  
Punta Gorda, FL 33982  
Phone: ++1(941) 575-3800  
Fax: ++1(941) 575-4085

An ISO 9001 and ISO 14001 Certified Company



CTI001 K11