

## VacuVibe

### Portable, Powerful Vibrator For Bulk Material Flow

The VacuVibe vacuum mount vibrator from NAVCO is a uniquely engineered for bulk material applications with occasional material flow problems. VacuVibe is designed to aid flow in bins, hoppers, and containers where traditional mounting techniques are not an option.

#### Built in the USA

Made in the USA, the NAVCO VacuVibe is designed and manufactured in Houston, TX.

#### Put the Hammer Down

Eliminate the need to hammer hoppers and bins to initiate and facilitate material flow. Utilizing a repetitive impact BH Vibrator, the VacuVibe breaks the friction that makes bulk materials bridge and rat hole.

#### Pneumatically Driven and Vacuum Mounted

From mounting the suction pad to powering the vibrator, the VacuVibe is designed to run completely on air making it ideal for incorporating into your processes

#### VacuVibe Goes Where Traditional Vibrators Can't

Traditional vibrators require a mount to be welded to the vessel. In situations where traditional mounting techniques, such as welding, are not an option, the NAVCO VacuVibe provides a powerful solution.

#### Designed for Portable, Powerful Vibration

Engineered for portability, the NAVCO VacuVibe is light enough to move around the facility with you and powerful enough to move material in vessels with walls up to 1/4" thick.



#### Impactful Vibration

Designed to maximize the bin response by utilizing a high-energy impulse. With each stroke of the vibrator the internal piston strikes the base of the unit transferring the maximum amount of linear force.

#### Mountable to a Wide Variety of Vessels

A powerful suction pad enables the NAVCO VacuVibe to mount to a wide variety of vessel types including: Bins, Chutes, Hoppers, Railcars, Hopper Bottom Trucks, and many more.

#### Move a Wide Variety of Materials

An all-purpose industrial vibrator, the NAVCO VacuVibe can initiate and facilitate flow across a wide variety of materials including: Grains, Feed, Chemicals, Powders, Dried Distillers Grain (DDG), Adipic Acid, and many more.

#### Safe, Portable Vibration

##### Clean Out

Ensure a more thorough and complete cleanout process without the hassle or danger of swinging hammers or climbing into vessels. The VacuVibe will help to remove long standing material that, if left, can cause corrosion and in some instances becomes a combustion hazard.

##### Protect Workers and Equipment

Eliminate the need to hit potential injury causing sledge hammers against your vessels to initiate material flow. The VacuVibe produces vibration powerful enough to break up material bridging and rat holes, while leaving vessels damage free.

##### Fall Protection Built In

Designed with worker safety in mind, the VacuVibe comes standard with a safety cable and quick release carabiner.



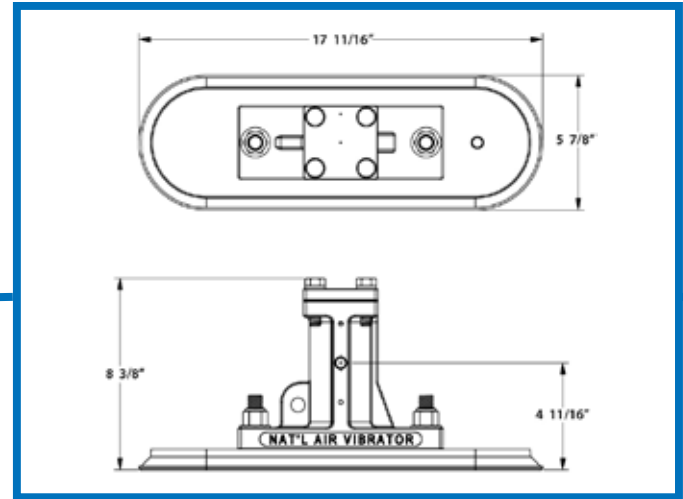
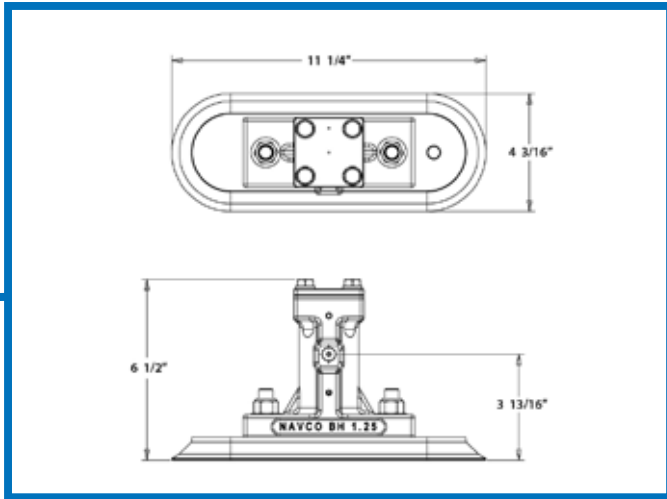

## VacuVibe 1.25

### Operating Characteristics

#### Frequency

Impacting (IT0WVM)	5,250 vpm
Silent (ST0WVM)	3,150 vpm

#### Air Consumption

##### Vibrator @ 50 psi

Impacting (IT0WVM)	4.2 SCFM
Silent (ST0WVM)	4.0 SCFM

##### Mount @ 100 psi

Vacuum Pad	18.0 SCFM
------------	-----------

#### Sound Pressure Level

Impacting (IT0WVM)	87 dBA
Silent (ST0WVM)	67 dBA

#### Weight

VacuVibe 1.25	16 lb
---------------	-------

## VacuVibe 2.00

### Operating Characteristics

#### Frequency

Impacting (IT0WVM)	4,750 vpm
Silent (ST0WVM)	2,100 vpm

#### Air Consumption

##### Vibrator @ 50 psi

Impacting (IT0WVM)	8.3 SCFM
Silent (ST0WVM)	8.0 SCFM

##### Mount @ 100 psi

Vacuum Pad	18.0 SCFM
------------	-----------

#### Sound Pressure Level

Impacting (IT0WVM)	106 dBA
Silent (ST0WVM)	73 dBA

#### Weight

VacuVibe 2.00	30.7 lb
---------------	---------

#### Included Accessories:

All VacuVibe Vibrators come complete with 14" of air hose, manual valves for vacuum pad and vibrator control, pressure regulator for vibrator operating pressure, 3/8" NPT male quick connect fitting, safety cable and latch.

#### Optional Accessories:

Filter Regulator Lubricator combo units available.

### CONTACT US TODAY AT

E. SALES@NAVCO.US W. NAVCO.US A. 11929 Brittmoore Park Dr.  
P. 832.467.3636 F. 832.467.3800 Houston, TX 77041