



ZERO SPEED SWITCHES

2100 Series

Operating Range: 4 to 2000 RPM

Electromechanical Rotary Motion Control Switches

Reduce downtime, protect expensive equipment and safeguard operations.



Stop an entire operation if one machine fails.

**No electrical input needed for operation • Shaft-driven
Corrosion-resistant housing**

DAZIC® Zero Speed Switches monitor the rotary motion of equipment when interlocked as part of a conveyor system, or other shaft-driven process components. The switches ensure that if one machine deviates or fails, the switch will:

- Actuate a signal or alarm device
- Break a circuit to a motor
- Make a circuit to start auxiliary equipment
- Make or break a circuit to other electrical devices
- Signal a control station or PLC

When driven from a critical shaft, a **Zero Speed Switch** will engage when a system's normal operating speed:

- Stops due to mechanical failure
- Slows down due to overload
- Changes due to normal machine cycling
- Begins to overspeed
- Reverses rotation

2100 Series	
Driver	Shaft-to-shaft
Shaft Diameter	1/2" (1.27 cm)
Operating Range	4 to 2000 RPM
Driver Torque Required	.0208 ft-lb (.0282 Nm)
Temperature Tolerance	-40 °F to +250 °F -40 °C to +121 °C
Housing Options	Aluminum (AL) or Cast Iron (CI)
NEMA Rating	4/4x
Mounting Options	Base, Flange or Flange with pilot
Dimensions L x W x H	6.02" x 4.25" x 3.93" (15.29 cm x 10.80 cm x 9.98 cm)
Wiring Contact Options	SPDT, DPDT, SPDT(2)
Weight	AL - 4 lbs. (1.81 kg) CI - 8 lbs. (3.63 kg)

Zero Speed Switches should be mounted to idler pulleys or tail shaft to sense the machinery's operation.

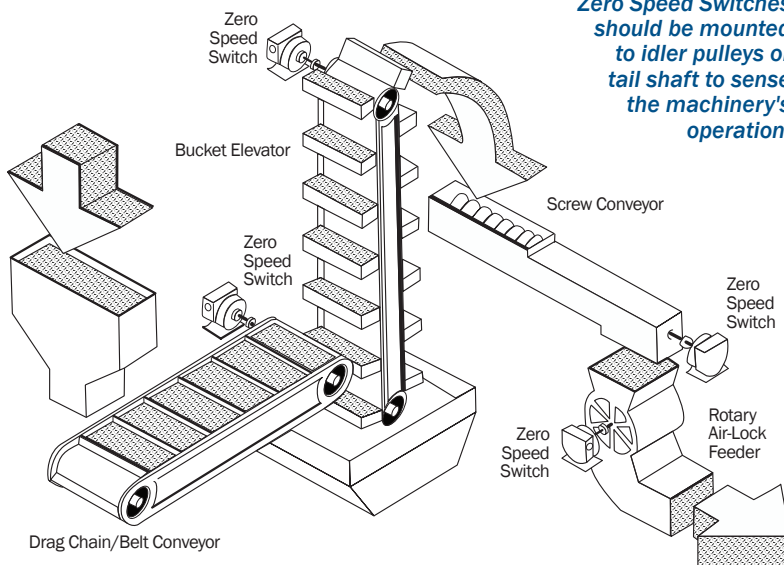

Explosion-proof Zero Speed Switch is available with NEMA 7/9 rating. Contact us for more information.



2100 Series Zero Speed Switches

Speed Switch Input (RPM) <small>(Application Running Speed)</small>		Approximate Contact Operating Speeds (RPM)			Contact Type			
		Start-Up Trip-Point Upon Initial Speed Switch Acceleration (RPM)	Drop-Out Point On Shaft Speed Loss (RPM)		SPDT <small>Single Pole, Double Throw</small>	DPDT <small>Double Pole, Double Throw</small>	SPDT(2) <small>Direction Indicating</small>	
MIN. RPM	MAX. RPM			SLOW LOSS	RAPID LOSS	Model No.	Model No.	Model No.
NOT FIELD ADJUSTABLE								
24	2000	14 to 19	10	0	2120	2122	2130	
15	200	8 to 11	Approx. 2 Sec. After Shaft Rotation Failure		2120-1	2122-1	2130-1	
8	100	5 to 7	Approx. 3 Sec. After Shaft Rotation Failure		2120-5	2122-5	2130-5	
4	50	2 to 3	Approx. 5 Sec. After Shaft Rotation Failure		2120-10	2122-10	2130-10	
FIELD ADJUSTABLE								
30	2000	25 to 70	30-40% Below Trip Point	0	2120-A1	2122-A1	2130-A1	
75	2000	60 to 140	30-40% Below Trip Point	0	2120-A2	2122-A2	2130-A2	
150	2000	125 to 450	30-40% Below Trip Point	0	2120-A3	2122-A3	2130-A3	
240	2000	200 to 600	30-40% Below Trip Point	0	2120-A4	2122-A4	2130-A4	
15	200	10 to 45	30-40% Below Trip Point	0	2120-A11	2122-A11	2130-A11	
7	100	5 to 15	30-40% Below Trip Point	0	2120-A15	2122-A15	2130-A15	

Mounting Styles:

Switches can be mounted in any position but they must be aligned and concentric with the corresponding drive shaft.

When ordering, please specify Mounting Style:

- Type B – Base Mount
- Type F – Flange Mount
- Type FK – Flange Mount w/ pilot



Model 2120 with Base mount (Type B)



Model 2120 with Flange mount with pilot (Type FK)

Electrical Wiring Options:

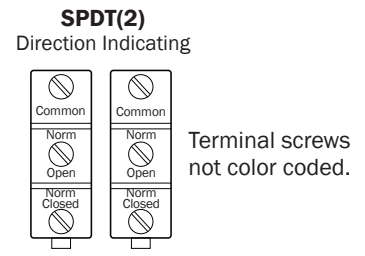
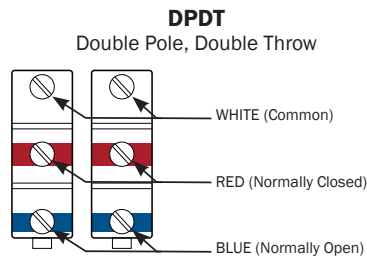
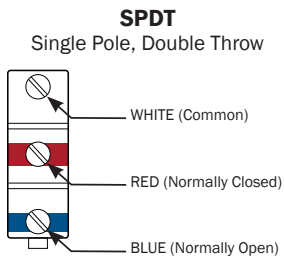

How to order:

Housing Material – Model No. – Mounting Style
(AL or CI) 21xx-xx (B, F or FK)

For example:

Model 2120-1 with Cast Iron housing and Base mount = CI-2120-1-B

2100 Series – Base Mount

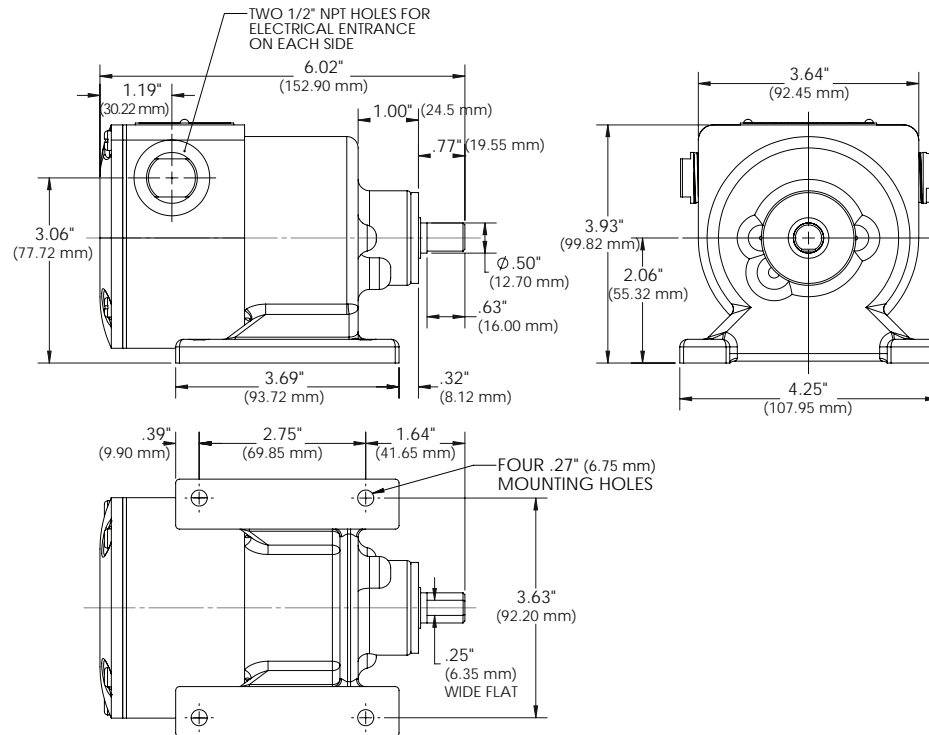

2100 Series – Flange Mount

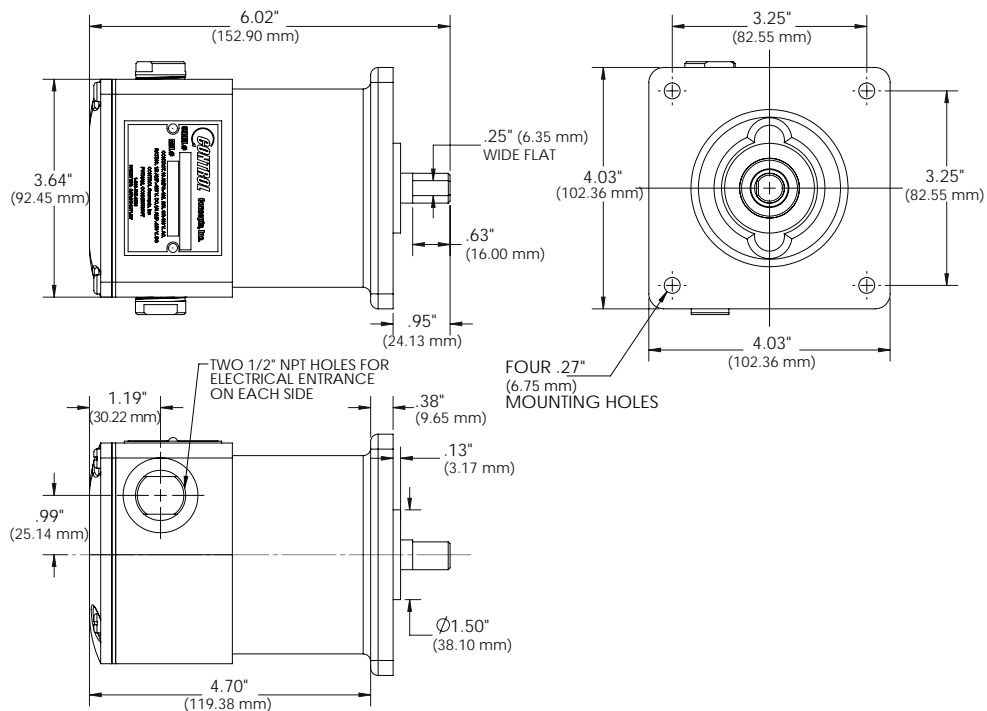

Speed Switch devices coupled to a corresponding shaft, must be properly mounted and aligned to avoid putting extra load on motor bearings, which may cause premature failure. The use of installation accessories such as Mounting Brackets and K-Couplings provide a secure foundation and eliminate misalignment connection problems.

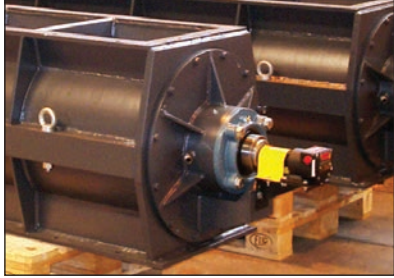

Zero Speed Switch mounted on rotary feeder.

Mounting Bracket

When ordering Mounting Brackets, please specify **Model MB-1** for 2100 Series Zero Speed Switches.

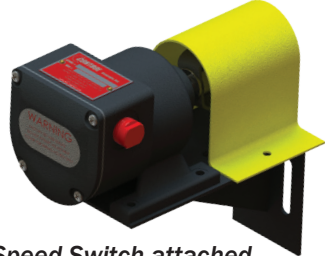
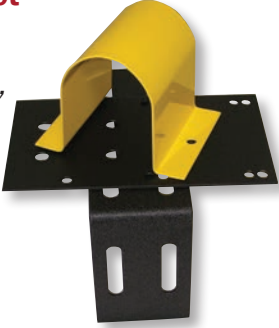

Speed Switch attached to a Mounting Bracket

K-Couplings

The K-Coupling® is made of double-loop ELASTACAST® polyurethane elastomeric material assembled to zinc plated steel hubs, which mount to shafts using Allen screws. Motor noise and vibration will be dampened. Bearings will last longer and require less maintenance.

When ordering, make sure the torque requirement is within rating limits, and always include the bore size for both ends of the coupling, which may not be the same. Example: 5801 1/4" x 5/16"

Notes:

- Bore tolerances are AGMA Class 2 - 000 + .002
- All standard coupling hubs are zinc plated steel

Keyways may be obtained on Series 5803 and 5804 couplings for an additional cost.

Standard keyways are: 1/8" for 1/2" dia. shaft; 3/16" for 9/16" and 5/8" dia. shafts

K-Couplings



Available Bore Sizes	Series 5801	Series 5802	Series 5803	Series 5804
3/16" (4.76 mm)	✓			
1/4" (6.35 mm)	✓	✓		
5/16" (7.94 mm)	✓	✓		
3/8" (9.53 mm)	✓	✓	✓	
7/16" (11.11 mm)		✓	✓	
1/2" (12.70 mm)		✓	✓	✓
9/16" (14.29 mm)			✓	✓
5/8" (15.88 mm)			✓	✓
Torque Capacity	0.25 ft-lb (0.34 Nm)	1.0 ft-lb (1.36 Nm)	2.33 ft-lb (3.16 Nm)	3.33 ft-lb (4.51 Nm)
Maximum Misalignment	10° angular 3/32" parallel	15° angular 1/8" parallel	15° angular 3/16" parallel	15° angular 1/8" parallel

Stub Shaft

Part No.	Shaft Diameter (A)	Thread Size (B)
STSH-500	1/2" (12.70 mm)	1/2-13 UNC-2A
STSH-625	5/8" (15.88 mm)	5/8-11 UNC-2A



STSH-500 Stub Shaft

Stub Shaft includes one Jam Nut