

BULLETIN 254A

INSTALLATION & OPERATION

SafePoint®

A Fail-Safe (Self-Validating) Rotary Paddle Bin Monitor



Thank you for purchasing a quality product manufactured by Monitor Technologies LLC. We realize that you do have a choice of vendors when procuring bin level monitors and we sincerely appreciate your business!



This manual contains the information necessary to ensure a safe and successful installation. Please read and comply with the section on page 8 of this manual pertaining to SAFETY. Doing so will ensure proper operation of the equipment and the safety of all personnel.



Before discarding shipping container, please inspect it thoroughly and verify that all parts ordered are accounted for. Sometimes smaller parts become stuck under carton flaps and other packaging materials.

In the event that information contained herein does not completely satisfy your requirements or answer your questions, you may contact Technical Support on our website www.monitortech.com, by telephone at 800-766-6486 (630-365-9403), or by email at techsupport@monitortech.com. If your **SafePoint®** ever requires service either in or out of warranty, please contact us and obtain an RMA number prior to shipping the unit to us.



www.monitortech.com

PRE-INSTALLATION CONSIDERATIONS

DIMENSIONS ARE SHOWN IN INCHES WITH MILLIMETER EQUIVALENT IN BRACKETS

Choosing a Location: (See Figure 1)

- 1) Material Flow** - When selecting a location for the **SafePoint**[®], choose a point in the vessel where the paddle will be out of the direct flow of incoming and outgoing material to prevent any mechanical damage that may be caused by the pressure of the flow. This is particularly important for materials with large, lumpy characteristics. The **SafePoint** must be positioned at a point where incoming material will reach and cover the paddle in its normal flow, and when receding, will flow away from the paddle in an even manner.
- 2) Vibration Concerns** - Mount at a location that is subject to limited vibration, away from bin vibrators thereby attaining maximum operational life. Consult the factory when questionable conditions exist.
- 3) Guard Reinforcement** - When using shaft extensions and guards in top mounted applications, select a location where it is feasible to reinforce the guard to the vessel wall. See Mechanical Installation portion of this bulletin for further details.

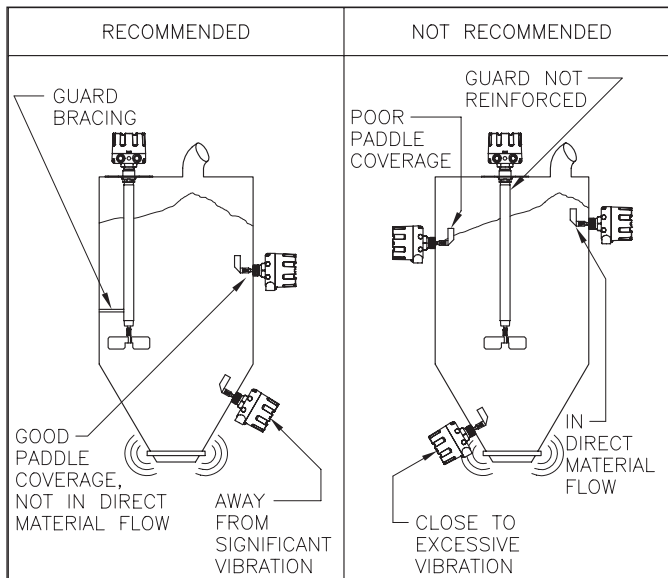

Figure 1

Protective Baffles: (See Figure 2)

The installation of protective baffles for low level monitoring is recommended for materials that weigh more than 65 lbs/ft³ (1050kg/m³), have a tendency to pack, bridge, arch, or have unusual flow characteristics. This baffle can be created using a number of materials including angle iron, welded plates and pipe sections. This structure will keep the full weight of the material from damaging the **SafePoint**. The baffle should be welded to the bin wall and should not extend more than 6 inches (152 mm) into the bin. Also, the lowest point of the baffle should be approximately 6 inches (152 mm) above the top of the paddle arc.

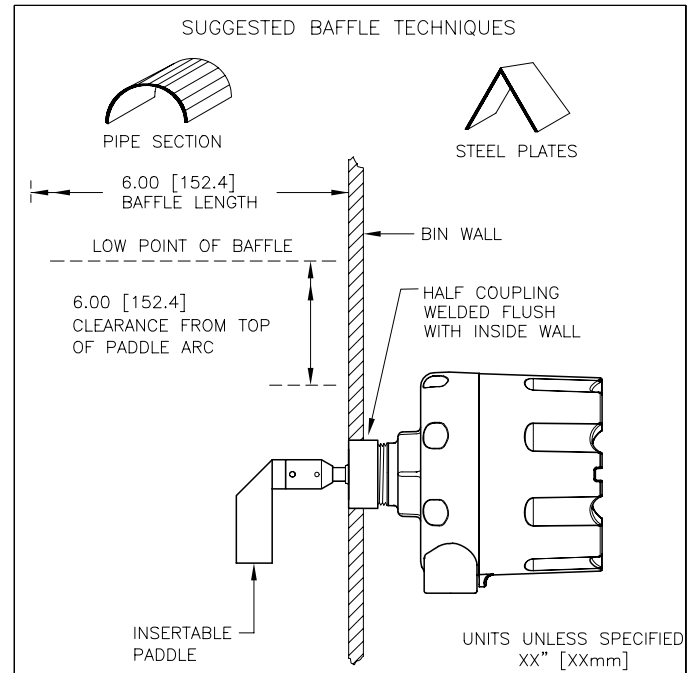

Figure 2

SafePoint Preparation: (See Figure 3)

- 1) Mounting Plate Attachment** (if applicable) - After using the mounting plate gasket as a mounting hole template, (See Mechanical Installation portion of this bulletin), attach the mounting plate to the **SafePoint** prior to attaching to vessel. This is particularly advantageous if the paddle to be used is not an "insertable" type. Grease the **SafePoint**'s threaded hub with anti-seize compound and thread the mounting plate into place until snug.
- 2) Flexible Coupling Attachment** (if applicable) - Remove lock pin from the **SafePoint**. Screw the flex coupling into the coupling provided on the **SafePoint**. Align "through hole" within the connection and secure with lock pin.
- 3) Extension Attachment** (if applicable) - Remove lock pin from **SafePoint** or flex coupling. Screw the extension into the coupling provided on the **SafePoint**, or flex coupling. Align "through hole" within the connection and secure with lock pin. Guards should be used with rigid extensions greater than 18 inches (457 mm) in length.
- 4) Guard Attachment** (if applicable) - In applications using a mounting plate with a full coupling, slide the 1-1/4" pipe over the shaft extension and secure to mounting plate coupling. The shaft extension should protrude from guard a distance of approximately 4 inches (102 mm). When not using a mounting plate, the guard must be connected to the **SafePoint** with a 1-1/4" full coupling and in some cases may require attachment after **SafePoint** installation to vessel.
- 5) Paddle Attachment** (if applicable) - Paddle should be attached at this time only if variety chosen is an "insertable" type or if mounting plate is being utilized. Remove lock pin from applicable connection point (i.e. bin monitor, flex coupling, or extension). Screw the paddle into the applicable coupling. Align "through hole" within the connection and secure with lock pin.

MECHANICAL INSTALLATION

Side Mount/Top Mount:

- 1) Coupling Mounting** - Cut a hole into the vessel that corresponds to the outer diameter of pipe coupling. In side mount applications, position a half-coupling flush with the inside of the vessel and weld into place. In top mount applications, position a full coupling halfway into the vessel and weld into place. After greasing the mounting threads with anti-seize compound, thread the **SafePoint®** into the coupling and position the conduit entrance to minimize moisture infiltration. Attach paddle if applicable. (See Figure 2)
- 2) Plate Mounting** - Using the gasket provided with the mounting plate as a template, drill six holes at the diameter applicable to the attachment method being used. Drill six clearance holes at 11/32 inch (9 mm) diameter for use with 5/16" bolts. The bolts may be secured by tack welding the bolt heads to the vessel, or by an adjoining nut. Cut a hole (suggested size 2-5 inches (50-125 mm)) centered within the bolt circle to allow an attached paddle to fit within the bin. Attach gasket and mounting plate to the vessel positioning the conduit entrance to minimize moisture infiltration. (See Figure 4)

DIMENSIONS ARE SHOWN IN INCHES WITH MILLIMETER EQUIVALENT IN BRACKETS

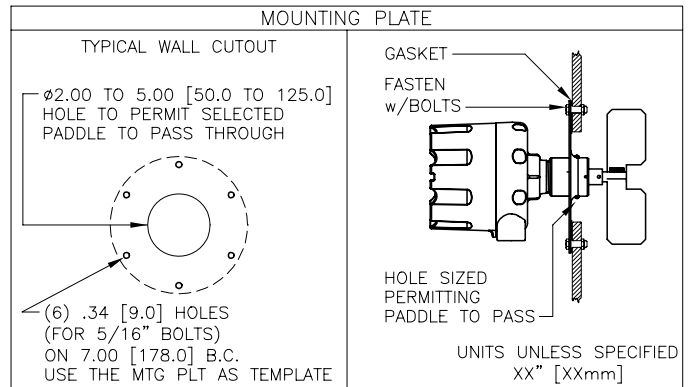

Figure 4

Extension/Guard Installation: (See Figure 5)

- 1) Typical Configuration** - Rigid extensions are recommended for top mount applications only and should be always accompanied by a flexible coupling. Shaft guards are recommended whenever extensions are longer than 18 inches (457 mm).
- 2) Guard Reinforcement** - Mechanical reinforcement of the shaft guard should be considered whenever a guard length greater than 72 inches (1.8 m) is used. The guard should be anchored to the sidewall with braces to reduce mechanical stress at the connection point of the guard.
- 3) Guard/Extension Multi-Stage Assemblies** - It may be necessary to connect multiple short pieces to ultimately achieve the desired length. In all cases, extensions and guards should not exceed 144 inches (3.6 m). Shaft extensions can be simply connected one to another. Guards must use a 1-1/4" full coupling as an interface between sections. Couplings are available from Monitor Technologies.
- 4) Cable Extensions** - Lengths up to 78 inches (2.0 m) are permitted. Length can be shortened in the field as required. See instructions provided with cable extension for details.

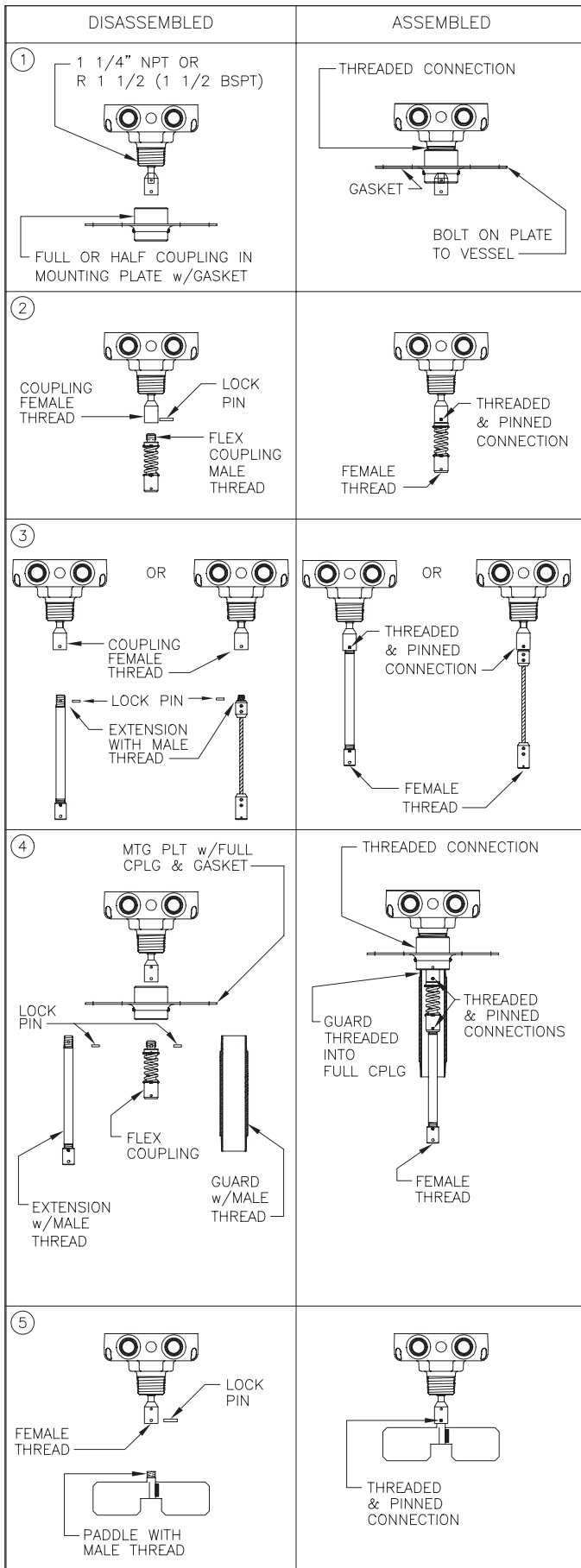
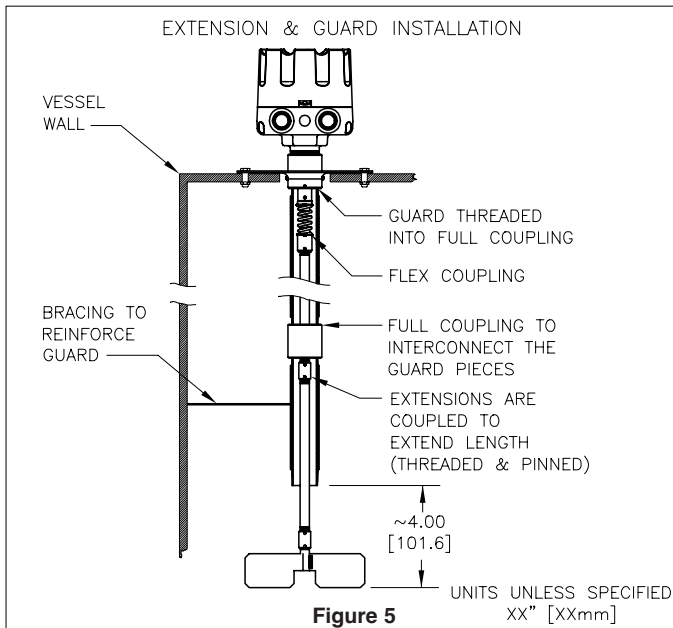

Figure 3



Hi-Temp. Models:

- 1) **Mounting** - Carefully handle the Hi-Temp. gasket provided with the assembly. Using it as a template, mark the locations of the six boltholes on the vessel. Drill six holes at the diameter applicable to the attachment method being used (i.e. tapped holes or clearance holes for bolt/nut combination). For example, drill six clearance holes at 11/32 inch (9 mm) diameter for use with 5/16" bolts. The bolts may be secured by tack welding the bolt heads to the vessel, or by an adjoining nut. Cut a hole (suggested size 2-5 inches (50-125 mm)) centered within the bolt circle to allow the paddle when attached to the **SafePoint**® to fit within the bin. Attach gasket and Hi-Temp. **SafePoint**® to the vessel positioning the conduit entrance in a manner, which restricts moisture infiltration.
- 2) **Extensions/Guards** - Use of extensions are permissible on Hi-Temp units also. (See Extension/Guard Installation section). Installing guards on Hi-Temp models requires in-field modifications. Consult factory for guidance.
- 3) **Effective Cooling** - The Hi-Temp. model includes a steel lagging pipe, which thermally insulates (via lag pipe material and physical separation) the internal bin temperature from the **SafePoint**® thereby protecting its critical components. This technique is very effective but is dependent on careful consideration of ambient air temperature surrounding the **SafePoint**®, thermal conductivity of the material being sensed, and the actual temperature present at the mounting point. The following chart is intended to provide general guidance for installation. Each application should be evaluated to insure that the rated temperature of the electronics is not exceeded. In addition, an air connection is provided on the lagged pipe to further increase the cooling capacity of the system. When applicable, connect airline to 1/2" coupling provided on Hi-Temp. model using only the recommended air pressure, which must exceed the bin pressure to be effective. The air should be clean and dry and is required to be continually supplied to the Hi-Temp. model to assure cooling.

Internal Temp.	Model	Air Required	CFM
< 250°F (121°C)	Standard	none	N/A
250-500°F (121-260°C) [without air-cooling]	Hi-Temp	none	N/A
500-750°F (260-400°C) [with air-cooling]	Hi-Temp	0.5 psig	2.14

- 1) **Hazardous Location Precautions** - (See Safety and Specifications sections of this manual before starting electrical installation.) Observe all government regulations regarding equipment in hazardous locations. In particular, for CSA approved explosion-proof products, install a conduit seal fitting within 2 inches (50 mm) of the **SafePoint**®. On all models ensure power is disconnected whenever the cover is removed and upon completion ensure cover is completely re-attached.
- 2) **Factory Wiring** - The **SafePoint**® motor leads are prewired to the PCB at the designations labeled "M1" and "M2". **DO NOT** alter or make additional external connection to these terminals. Doing so will likely cause damage to the **SafePoint**.
- 3) **Permanently Connected Equipment** - Disconnecting devices shall be included in the system installation. In installations where multiple circuits are used, individual disconnects are required. The disconnects shall be within close proximity of the equipment, accessible to operators, and marked appropriately as the disconnect for the associated circuit. Assure the disconnect ratings are appropriately sized for the circuit protected (See Specifications).
- 4) **Circuit Separation** - Since the **SafePoint**®'s single wiring compartment can not absolutely protect against physical contact between multiple circuits, it is required that all wiring used must have an insulation rating of 300v minimum, and a temperature rating of 194°F (90°C) minimum.
- 5) **Protective Earthing** - Each **SafePoint**® is provided with a "protective conductor terminal" ⊕ which shall be terminated to the local earth ground potential to eliminate shock hazard. Select wire size that can carry in excess of the sum of all circuit's maximum amperage.
- 6) **Power Input** - Verify the intended voltage supply is compatible with the voltage configuration indicated on the electronics and the external nameplate. Connect power as shown in Figure 6. The 24 VAC/DC model must be supplied by a SELV source. Observe polarity when using a VDC source.
- 7) **Sense Output Contacts** - The **SafePoint**® is equipped with a set of isolated contacts (SPDT) which indicates whether or not material is being detected within the vessel (See Figures 6-8). This output is also influenced by the selection of the "fail-safe" switch as described in the "Setup" section of this manual. The designations on the circuit board relate to the contact status when the relay is de-energized (e.g. the material is "not" sensed and the fail-safe switch is in the "low" mode).
- 8) **Fault Output Contacts** - The **SafePoint**® is equipped with a set of isolated contacts (SPDT) that indicates whether or not the unit's self-diagnostics detected successful operation (See Figures 6-8). The designations on the circuit board relate to the contact status when the relay is de-energized (e.g. the power is removed or when an internal error is detected). In normal operation, the "fault" relay will be energized resulting in a closed "normally open" contact, and an open "normally closed" contact. This output can be wired in tandem with the Sense Output Contacts to provide an output that combines the material sense and fault detection on a single wire set.

SETUP

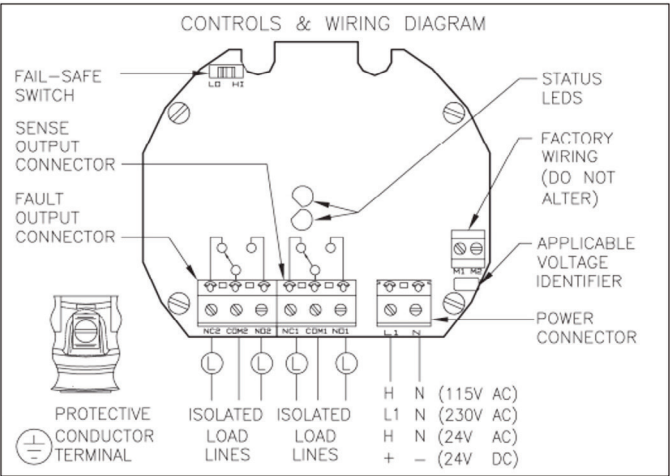

Figure 6

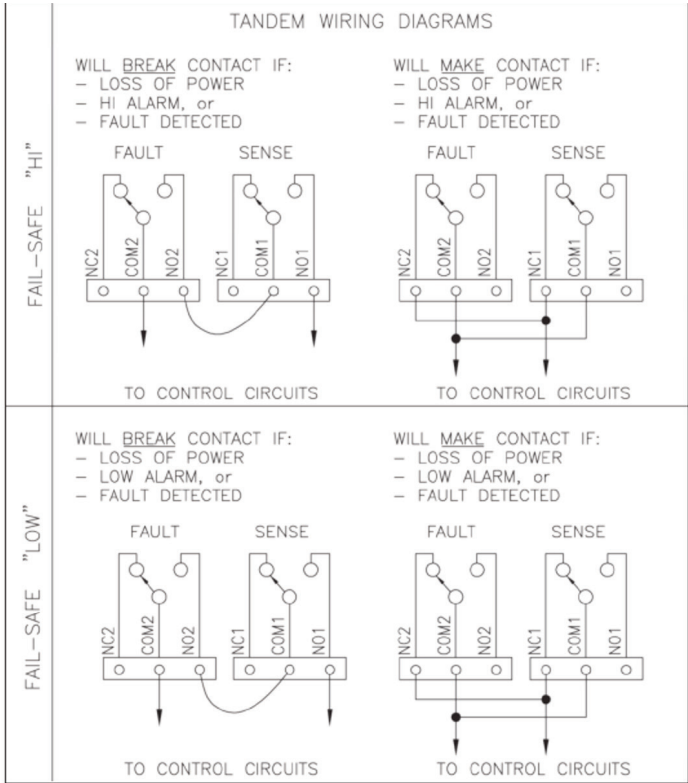

Figure 7

	INITIALIZATION	NORMAL SENSING CONDITIONS		POWER FAILURE	FAULT DETECTION
FAIL-SAFE "HI"					
FAIL-SAFE "LOW"					

Figure 8

Sensitivity (Paddle Selection)

Paddle selection determines the sensitivity of the **SafePoint®**. There is no sensitivity adjustment within the unit. Ensure that the paddle being used for the application corresponds with the recommendations found in Monitor's Material Characteristics Guide (Bulletin 115A).

Status LEDs (See Figure 6)

Ordinary location models have LEDs located on the circuit board which are also visible externally through the lens on the center of the cover. Hazardous models' LEDs are not viewable externally.

- 1) Green-flash** - "Initialization" in process. For 30 seconds (max) after power is applied, the green LED will flash while self-diagnostics is performed. The "sense" output will indicate if material is sensed (Note: influenced by "fail-safe" switch setting). The "fault" output will remain "de-energized".
- 2) Green-steady** - "No material is being sensed" and self-diagnostics has passed. The "sense" output will indicate no-material-sensed (Note: influenced by "fail-safe" switch setting). The "fault" output will be "energized".
- 3) Red-steady** - "Material is being sensed" and that self-diagnostics has passed. The "sense" output will indicate material-sensed (Note: influenced by "fail-safe" switch setting). The "fault" output will be "energized".
- 4) Red-flash** - A "fault" has been detected in the self-diagnostics. The "sense" output will default to the no-material sensed state (Note: influenced by "fail-safe" switch setting). The "fault" output will be "de-energized".

Fail-Safe (See Figure 8)

The "fail-safe" switch setting only influences the "sense" output (never affects the "fault" output). Generally the "fail-safe" switch is set so in the event of a power failure, the "sense" output will default to the application's critical state condition.

- 1) High Fail-Safe** - The "sense" output will de-energize when material is sensed at high level or with power loss.
- 2) Low Fail-Safe** - The "sense" output will de-energize when material is below low level or with power loss.

Designations on the electronics refer to the relay contact status when no material is sensed and the "low" fail-safe is selected (Relay is de-energized). Contacts are reversed when no material is sensed and high fail-safe is selected (Relay is energized).

TROUBLESHOOTING

PROBLEM: The SafePoint® indicates "fault" via its relay output and red flashing LED

CAUSE/SOLUTION:

- 1) Verify electrical power is connected to the proper terminations and that it is the proper voltage as depicted on the cover.
- 2) Verify motor leads (and only the motor leads) are connected to the terminal block locations M1 and M2.
- 3) Verify voltage between the M1 and M2 positions. The voltage should be 115VAC for 115VAC models, 230VAC for 230VAC models, and 24VAC for 24VDC/AC models. If correct voltage is present, motor should rotate. Replace motor if necessary.
- 4) Verify clutch operation by manually rotating paddle until motor mounting plate reaches its stops. Replace clutch if manual rotation can not cause motor mounting plate to reach stops.
- 5) Verify gap between ring magnet and small encoder PCB. Gap to be roughly 1/16". Significant misalignment will require factory evaluation and repair.

PROBLEM: The paddle does not rotate when material is absent and the sensor is in "sense" mode

CAUSE/SOLUTION:

- 1) Verify condition of sensitivity spring. It should not be cut, broken or excessively stretched to the point that it loses its ability to retract motor to "no sense" condition. Replace if necessary.
- 2) Verify status of material around shaft and hub of rotary paddle bin monitor. Excessive buildup may restrict shaft from returning to "no sense" condition. Clean material buildup.
- 3) Verify if drive shaft is free to rotate by manually twisting paddle. If rotation is restricted, replace the outer seal and the two internal bearings.

PROBLEM: The paddle rotates but material is not sensed when the paddle is covered.

CAUSE/SOLUTION:

- 1) Verify that the paddle being used in the application follows the guidelines outlined in the Material Characteristics Guide (Bulletin 115A). Change paddle to one capable of sensing lighter material.
- 2) Verify that motor mounting plate rotates freely between its two mechanical stops. Ensure spring extends uniformly without binding. Replace spring if necessary.
- 3) Verify gap between motor mounting plate and small encoder PCB. Gap to be roughly 1/16". Significant misalignment will require factory evaluation and repair.

MAINTENANCE

⚠ Fuse Replacement

The fuses incorporated into the **SafePoint®** PCBs are intended for factory replacement only. If failure occurs, consult the factory for return of **SafePoint®**, or for additional technical information.

Cleaning Requirements

The hazardous and environmental protection techniques are functional only when the cover is completely installed on to the housing. If necessary, clean the cover/housing threads to permit complete thread engagement. Do not alter the threads and ensure O-ring is in place and free of contaminants.

Motor Replacement: (See Figure 9)

- 1) Disconnect power source from **SafePoint®**.
- 2) Disconnect motor leads that protrude from center of PCB and attach to "M1" and "M2" terminals.
- 3) Remove the four screws securing the PCB to the chassis. Pull motor leads through the grommet in the PCB. Leave power and output connections in place and drape the PCB over the side of the housing so the motor is completely accessible.
- 4) Remove the two screws holding the motor to the plastic mounting/actuator plate.
- 5) Install new motor and retain with two screws.
- 6) Pass the motor leads through the grommet in the center of the PCB. Re-attach PCB to the chassis with the four screws.
- 7) Fasten motor leads to "M1" and "M2" terminals on the PCB. Pull all excess wire up through the grommet on the PCB.
- 8) Reconnect the power source to the **SafePoint®**.

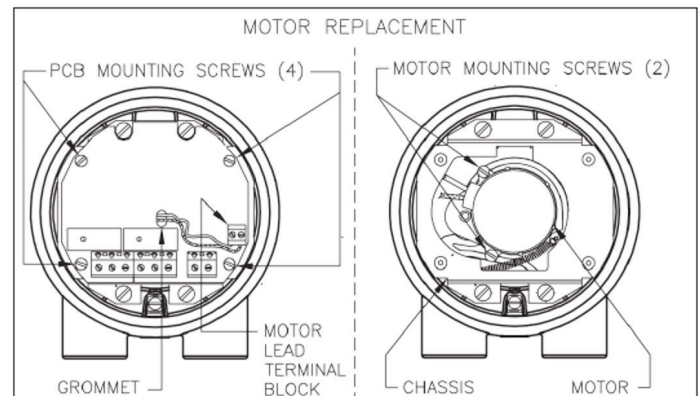
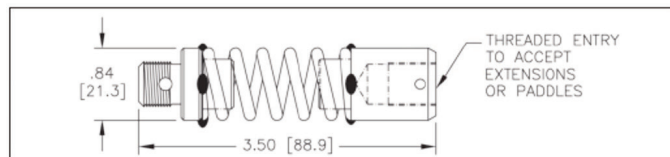
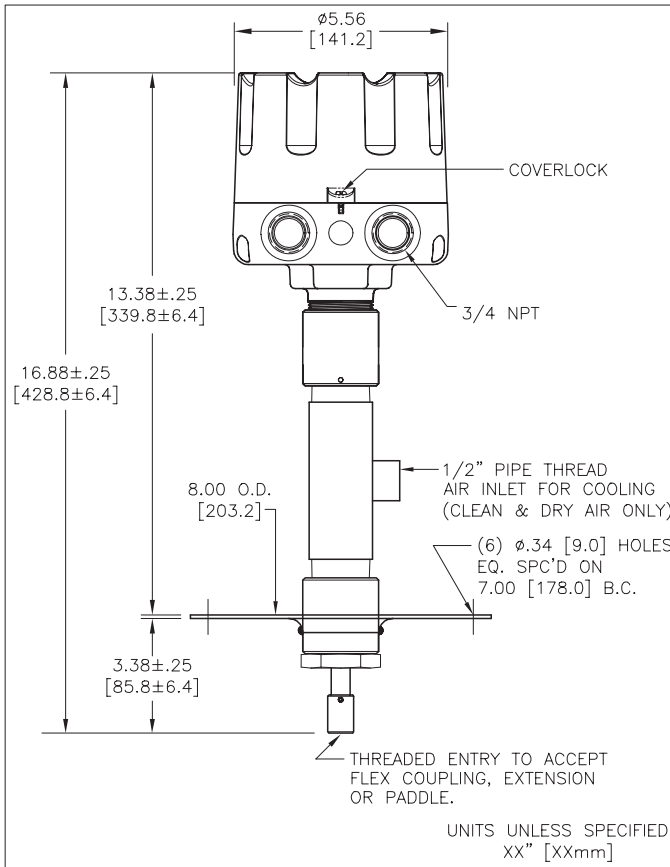
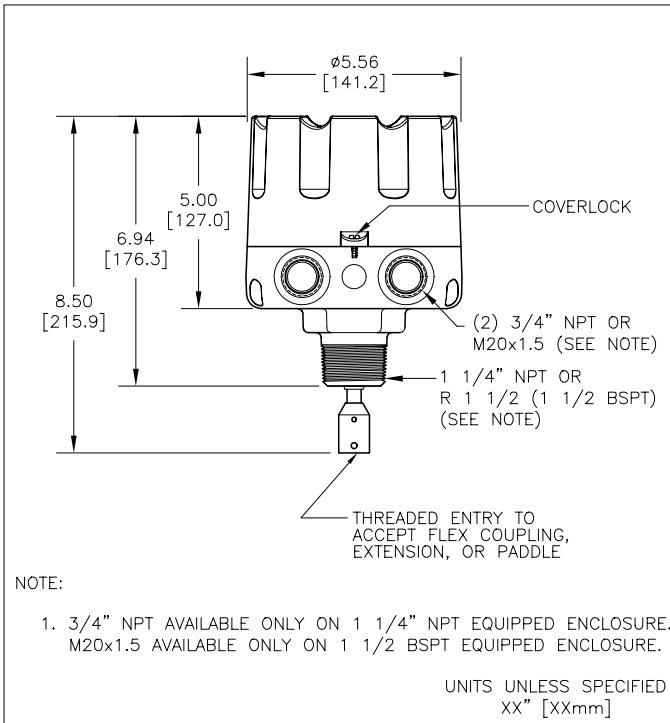

Figure 9

MECHANICALS

DIMENSIONS ARE SHOWN IN INCHES WITH MILLIMETER EQUIVALENT IN BRACKETS



Flexible coupling

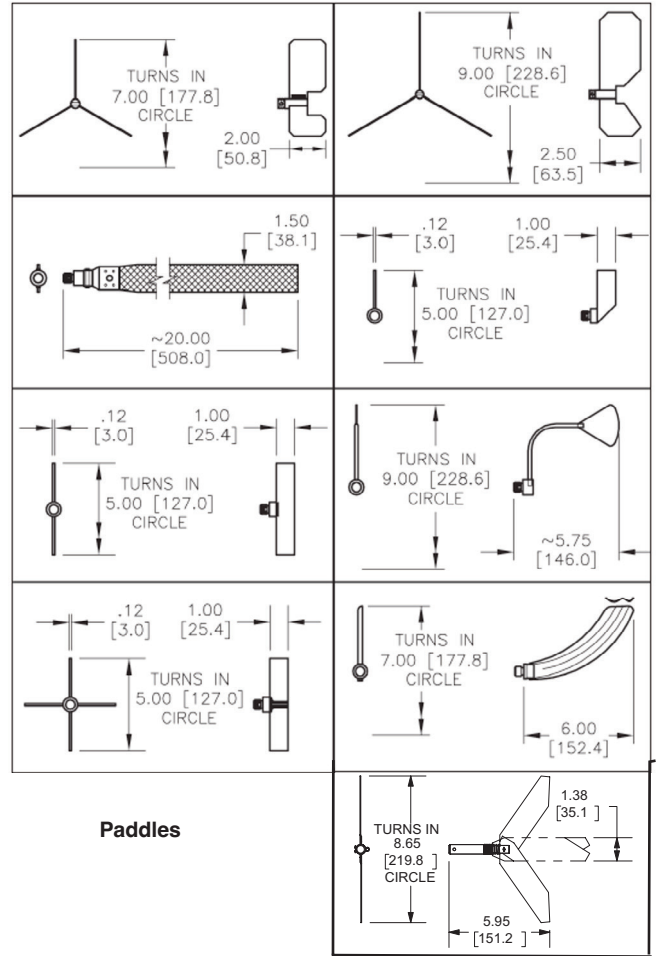

Paddles

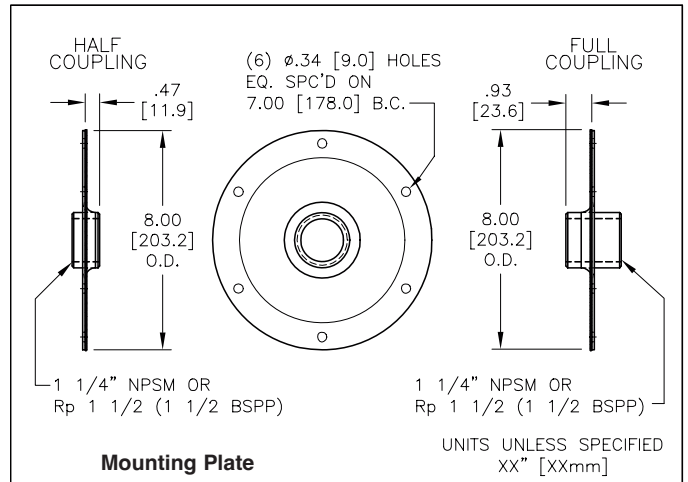

Mounting Plate

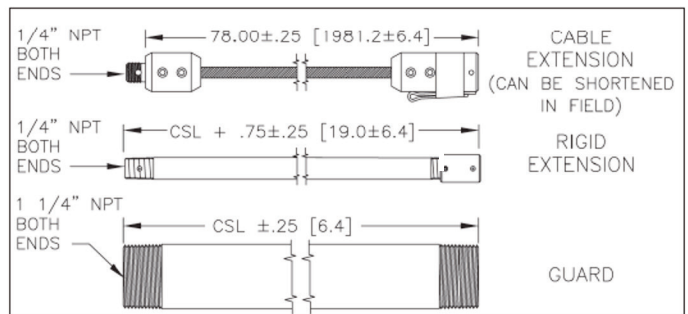

Extensions and guards

SAFETY

⚠️ General Safety

CAUTION: It is essential that all instructions in this manual be followed to ensure proper operation of the equipment and safety of operating personnel. Use of equipment not specified herein, may impair protection provided by equipment. The use of this symbol is used throughout manual to highlight important safety issues.

⚠️ Electrical Shock Caution:

Certain **SafePoint**® bin monitors are powered with HIGH VOLTAGE. No operator serviceable parts are inside. All servicing is to be performed by qualified personnel. Each **SafePoint**® is provided with a "protective conductor terminal" ⊕ which shall be terminated to earth ground potential (see Electrical Installation). This product's design complies with EN61010-1 installation category II and pollution degree 2.

⚠️ Hazardous Location Caution

Certain **SafePoint**® bin monitors can be used in Hazardous Locations (See specifications). These models shall only be used in applications covered by stated ratings or those considered non-hazardous. Failure to comply could result in damage to personnel and property. The following must be maintained to assure safe operation:

- 1) Enclosure integrity** - The **SafePoint**® is manufactured from aluminum and stainless steel with nitrile rubber seals. The user or installer should consider the performance of these materials with regard to attack by aggressive substances that may be present in a hazardous location. The dimensions of the housing, cover or drive-shaft shall not be altered.
- 2) Maintenance** - Power to all circuits must be disconnected before conducting any investigation, setup or maintenance.

Electromagnetic Compatibility (EMC)

The **SafePoint**® was tested and found to comply with the standards listed below. The **SafePoint**® should not be used in the residential or commercial environments. Compliance to the EMC standards was demonstrated using the following installation methods.

- 1) SafePoint**® enclosure was connected to protective earth ground.
- 2) No specific wiring convention** was used to supply power or to retrieve output signal from the **SafePoint**.

EMC Emissions:

Meets	EN 61326-1	Electrical Equipment for Control Use, EMC
	EN 55011	Radiated and conducted emissions (Class A- industrial)
	EN 61000-3	Fluctuations/Flicker
Meets	FCC Part 15B: CISPR 11	RF Devices, Unintentional Radiators Radiated and conducted emissions (Class A- industrial)

EMC Immunity:

Meets	EN 61326-1	Electrical Equipment for Control Use, EMC
	IEC 1000-4-2	Electrostatic discharge (industrial)
	IEC 1000-4-3	RF radiated EM fields (industrial)
	IEC 1000-4-4	Electrical fast transients (industrial)
	IEC 1000-4-5	Electrical surges (industrial)
	IEC 1000-4-6	RF conducted EM energy (industrial)
	IEC 1000-4-8	Power frequency magnetic fields (industrial)
	IEC 1000-4-11	Source voltage deviation

SPECIFICATIONS

General:

Power Requirements:	115 VAC (+/- 10%); 9 VA; 50/60 Hz 230 VAC (+/- 10%); 9 VA; 50/60 Hz 24 VAC/DC (+/- 15%); 11 VA
Altitude:	6562 ft (2000 m) max
Relative Humidity:	Suitable for outdoors
Installation Category:	II
Pollution Degree:	4 (Reduced to 2 via enclosure)
Ambient Operating Temp:	-40°F (-40°C) to +150°F (+65°C)
Internal Bin Temp:	
Standard Unit:	to +250°F (+121°C)
Hi-Temp Unit:	to +750°F (+400°C)
Conduit Connection:	Two(2) 3/4" NPT; M20 cable glands (Ordinary Location units with 1-1/2" BSPT process connection only; Not provided on Haz Loc units)

Outputs:	
Material Sense:	One SPDT; 5A @ 250 VAC, 30 VDC max
Unit Status (Fault):	One SPDT; 5A @ 250 VAC, 30 VDC max
Maximum Pressure:	30 PSI (2 bar)
Sensitivity:	5 lb./ft ³ (80 kg/m ³) minimum material density (when using large 3-vane paddle)

Indicators:	Red and green high intensity LEDs indicate material sense and unit status conditions (Ordinary Location unit only)
-------------	--

Housing:	Die cast aluminum, NEMA 4 / ENCLOSURE TYPE 4, IP66
----------	--

Housing Finish:	Powder coating
Mounting Connection:	1-1/4" NPT or R 1-1/2 (BSPT 1-1/2)
Weight:	Approx. 6 lb. (2.72 kg) with paddle

Materials of construction/accessories:

Flexible Couplings:	304 stainless steel
Mounting Plates:	Carbon steel or 304 stainless steel
All Paddles except Ex-Flex:	304 SS
Ex-Flex Belt:	304 SS coupling, rubber/fabric blend belt
Flexible Cable Extension:	304 SS 1/4" diameter
Shaft Seal:	Nitrile

Listings/Approvals:	CSA _{USC} : Ordinary Locations; Class I, Div. 1&2, Groups C, D; Class II, Div. 1&2, Groups E, F, G ATEXUKEx: Ⓢ II 1/2 D
----------------------------	---

Ex ta/tb IIIC T85°C Da/Db
Ex h IIIC T85°C Da/Db
(Ta -40°C to +65°C)
ATEX certificate #Sira 03ATEX9340
UKEx certificate #CSAE 21UKEX9587
IECEX: Ex ta/tb IIIC T85°C Da/Db

All Models:	 CE Mark
	 UKCA Mark
	 CHINA RoHS 2

U.S. Patent Pending

WARRANTY

Monitor Technologies LLC warrants each **SafePoint**® rotary paddle bin indicator it manufactures to be free from defects in material and workmanship under normal use and service within two (2) years from the date of purchase. The purchaser must give notice of any defect to Monitor within the warranty period, return the product intact and prepay transportation charges. The obligation of Monitor Technologies LLC under this warranty is limited to repair or replacement at its factory. This warranty shall not apply to any product which is repaired or altered outside of the Monitor Technologies LLC factory, or which has been subject to misuse, negligence, accident, incorrect wiring by others or improper installation. Monitor Technologies LLC reserves the right to change the design and/or specifications without prior notice.