

Electromechanical Rotary Motion Control Switches

Reduce downtime, protect expensive equipment and safeguard operations.



8100 Series Zero Speed Switches are ideal for slow speed applications.

Stop an entire operation if one machine fails.

**No electrical input needed for operation • Shaft-driven
Ideal for slow shaft speeds • Corrosion-resistant housing**

DAZIC® Zero Speed Switches monitor the rotary motion of equipment when interlocked as part of a conveyor system, or other shaft-driven process components. The switches ensure that if one machine deviates or fails, the switch will:

- Actuate a signal or alarm device
- Break a circuit to a motor
- Make a circuit to start auxiliary equipment
- Make or break a circuit to other electrical devices
- Signal a control station or PLC

When driven from a critical shaft, a **Zero Speed Switch** will engage when a system's normal operating speed:

- Stops due to mechanical failure
- Slows down due to overload
- Changes due to normal machine cycling
- Begins to overspeed
- Reverses rotation

8100 Series	
Driver	Shaft-to-shaft
Shaft Diameter	1/2" (1.27 cm)
Operating Range	0.5 to 25 RPM
Driver Torque Required	.0208 ft-lb (.0282 Nm)
Temperature Tolerance	-40°F to +250°F -40°C to +121°C
Housing Options	Aluminum (AL) or Cast Iron (CI)
NEMA Rating	4 / 4x
Mounting Options	Base, Flange or Flange with pilot
Dimensions L x W x H	6.02" x 4.25" x 3.93" (15.29 cm x 10.80 cm x 9.98 cm)
Wiring Contact Options	SPDT, DPDT, SPDT(2)
Weight	AL - 4 lbs. (1.81 kg) CI - 8 lbs. (3.63 kg)

Explosion-proof Zero Speed Switch is available with NEMA 7/9 rating. Contact us for more information.

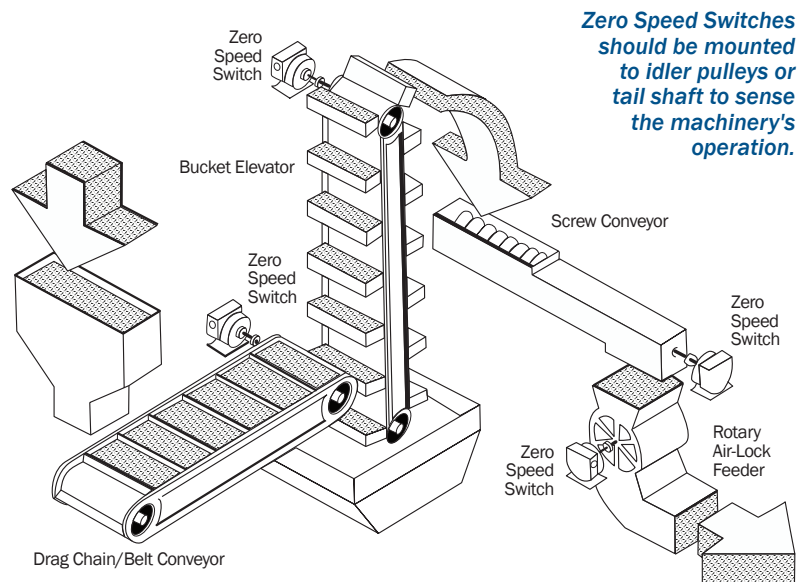

8100 Series Zero Speed Switches

Not Field Adjustable

Speed Switch Input (RPM) <small>(Application Running Speed)</small>		Approximate Contact Operating Speeds (RPM)			Contact Type		
		Start-Up Trip-Point Upon Initial Speed Switch Acceleration (RPM)	Drop-Out Point On Shaft Speed Loss (RPM)		SPDT <small>Single Pole, Double Throw</small>	DPDT <small>Double Pole, Double Throw</small>	SPDT(2) <small>Direction Indicating</small>
MIN. RPM	MAX. RPM			SLOW LOSS	RAPID LOSS	Model No.	Model No.
1.5	5	1.5	0.5	0	8121	81212	8131
0.5	2.5	0.5	Approx. 4 Sec. After Shaft Rotation Failure		8121-5	81212-5	8131-5
2	25	1.5	Approx. 3-5 Sec. After Shaft Rotation Failure		8122-5	81222-5	8132-5

Mounting Styles:

Switches can be mounted in any position but they must be aligned and concentric with the corresponding drive shaft.

When ordering, please specify Mounting Style:

- Type B – Base Mount
- Type F – Flange Mount
- Type FK – Flange Mount w/ pilot



Model 8121 with Base mount (Type B)



Model 8121 with Flange mount with pilot (Type FK)

Electrical Wiring Options:

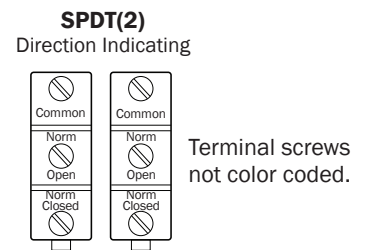
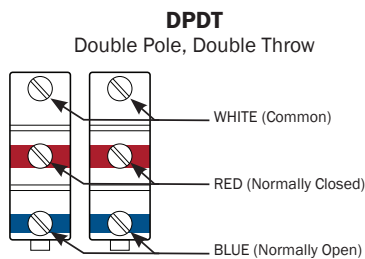
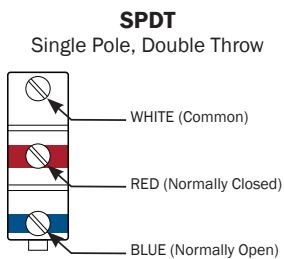

How to order:

Housing Material – Model No. – Mounting Style
(AL or CI) 81xx-xx (B, F or FK)

For example:

Model 8121-5 with Cast Iron housing and Base mount = **CI-8121-5-B**

8100 Series – Base Mount

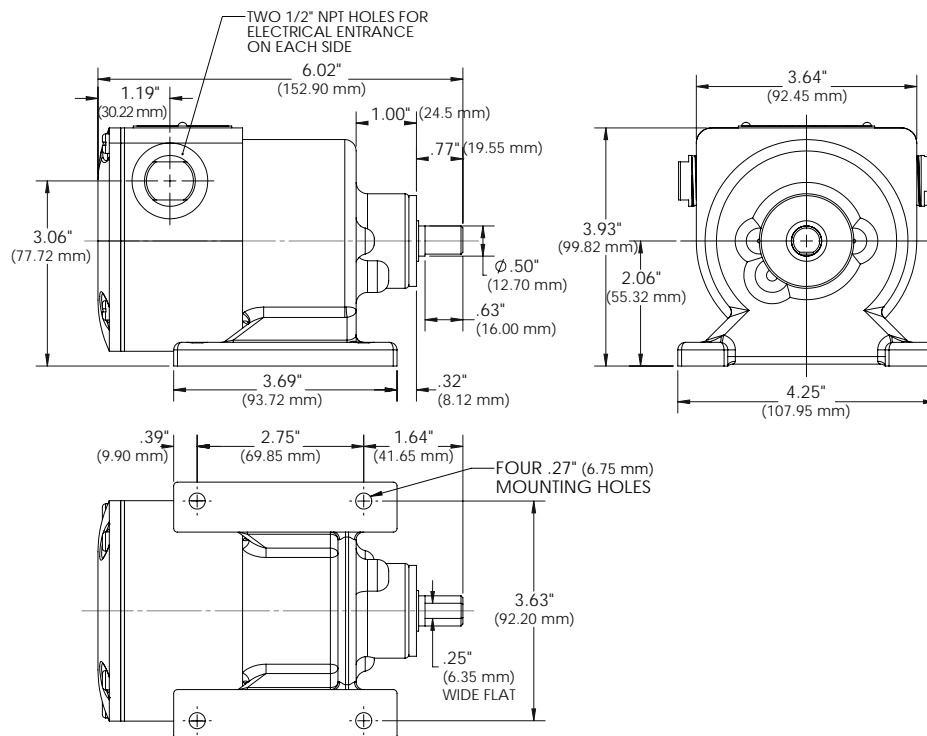

8100 Series – Flange Mount

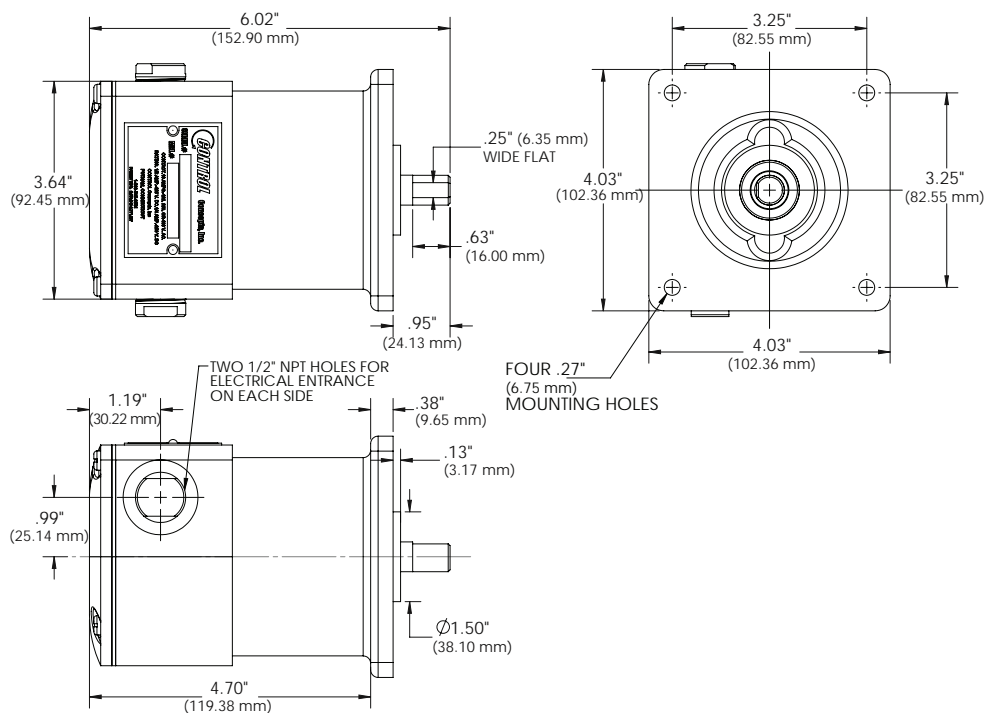

Speed Switch devices coupled to a corresponding shaft, must be properly mounted and aligned to avoid putting extra load on motor bearings, which may cause premature failure. The use of installation accessories such as Mounting Brackets and K-Couplings provide a secure foundation and eliminate misalignment connection problems.

Mounting Bracket

When ordering Mounting Brackets, please specify **Model MB-1** for 8100 Series Zero Speed Switches.

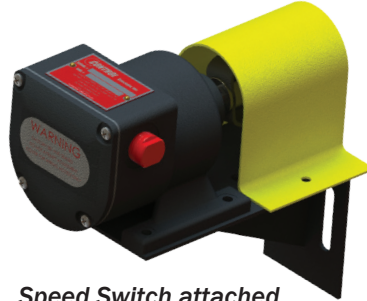
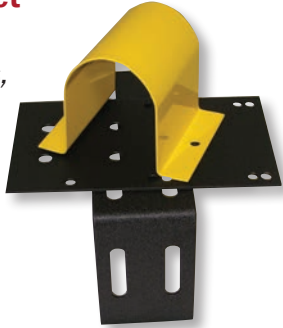

Speed Switch attached to a Mounting Bracket

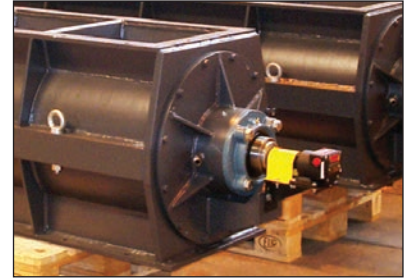

Zero Speed Switch mounted on rotary feeder.

K-Couplings

The K-Coupling[®] is made of double-loop ELASTACAST[®] polyurethane elastomeric material assembled to zinc plated steel hubs, which mount to shafts using Allen screws. Motor noise and vibration will be dampened. Bearings will last longer and require less maintenance.

K-Couplings



When ordering, make sure the torque requirement is within rating limits, and always include the bore size for both ends of the coupling, which may not be the same. Example: 5801 1/4" x 5/16"

Notes:

- Bore tolerances are AGMA Class 2 - 000 + .002
- All standard coupling hubs are zinc plated steel

Keyways may be obtained on Series 5803 and 5804 couplings for an additional cost.

Standard keyways are: 1/8" for 1/2" dia. shaft;
3/16" for 9/16" and 5/8" dia. shafts

Available Bore Sizes	Series 5801	Series 5802	Series 5803	Series 5804
3/16" (4.76 mm)	✓			
1/4" (6.35 mm)	✓	✓		
5/16" (7.94 mm)	✓	✓		
3/8" (9.53 mm)	✓	✓	✓	
7/16" (11.11 mm)		✓	✓	
1/2" (12.70 mm)		✓	✓	✓
9/16" (14.29 mm)			✓	✓
5/8" (15.88 mm)			✓	✓
Torque Capacity	0.25 ft-lb (0.34 Nm)	1.0 ft-lb (1.36 Nm)	2.33 ft-lb (3.16 Nm)	3.33 ft-lb (4.51 Nm)
Maximum Misalignment	10° angular 3/32" parallel	15° angular 1/8" parallel	15° angular 3/16" parallel	15° angular 1/8" parallel

Stub Shaft

Part No.	Shaft Diameter (A)	Thread Size (B)
STSH-500	1/2" (12.70 mm)	1/2-13 UNC-2A
STSH-625	5/8" (15.88 mm)	5/8-11 UNC-2A



STSH-500 Stub Shaft

Stub Shaft includes one Jam Nut