

Compact Magneto-Inductive Flowmeter

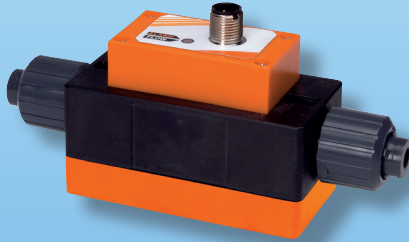

measuring
•
monitoring
•
analyzing

MIK



- Flow Ranges: 0.18...7.8 GPH to 9...180 GPM
- Accuracy: $\pm 2\%$ of Full Scale
- p_{\max} : 145 psi; t_{\max} : 176 °F
- Connection: G $\frac{1}{2}$...G 2 $\frac{1}{4}$ Male with Optional NPT, Socket, and Hose Connections
- Materials: PPS Body with Stainless Steel or Hastelloy® Electrodes; PVDF Body with Hastelloy® or Tantalum Electrodes
- Electronic Packages: Frequency, Current or Voltage Outputs, Adjustable Switches, and Integral Totalizers or Batch Controllers
- Highlights:
 - No Moving Parts in the Flow Body
 - Low Pressure Loss
 - Universal Mounting
 - High Quality at a Low Price



KOBOLD companies worldwide:

AUSTRALIA, AUSTRIA, BELGIUM, BULGARIA, CANADA, CHINA, CZECHIA, FRANCE, GERMANY, GREAT BRITAIN, HUNGARY, INDIA, INDONESIA, ITALY, MALAYSIA, MEXICO, NETHERLANDS, PERU, POLAND, REPUBLIC OF KOREA, RUSSIA, SPAIN, SWITZERLAND, THAILAND, TUNISIA, TURKEY, USA, VIETNAM

KOBOLD Instruments, Inc.
1801 Parkway View Drive
Pittsburgh, PA 15205
Main Office:
1.800.998.1020
1.412.788.4890
info@koboldusa.com
www.koboldusa.com



Description

The KOBOLD MIK flow meter is used for measuring and monitoring small to medium-sized flows of conductive liquids in pipes. The sensor operates according to the electromagnetic measurement principle. According to Faraday's Law of magnetic induction, a voltage is induced in a conductor moving through a magnetic field. The electrically conductive media acts as the conductor. The voltage induced in the media is proportional to the flow velocity and is therefore a value for the volumetric flow. The media must have a minimum conductivity of 30 µS /cm (200 µS /cm for U0 & U1 ranges) for proper operation. The induced voltage is picked up by two sensing electrodes which are in contact with the media and sent to the measuring amplifier. The flow rate will be calculated based on the cross sectional area of the pipe.

The measurement is not dependent on the process liquid and its material properties such as density, viscosity, and temperature. The device may be equipped with a switch, frequency, or analog output. The device also has a universal compact-ttype electronic which features two configurable outputs and a rotatable display.

Compact Electronic Features

- Flow and Temperature Measurement
- Switching, Transmitting, and Batching Functions
- Batching Function with External Control Input
- Colored, Multi-parameter Configurable TFT-Display, Rotatable in 90° steps
- Bi-Directional Flow Measurement
- Intuitive Setup Menu via 4 Optical Touch Keys
- 2 Configurable Outputs (Pulse/Frequency/Alarm/Analog Output)
- Grand and Resettable Totalizer
- IO Link Function

Media

- Conductive Liquids
- Acids and Caustic Solutions
- Ground Water, Raw Water
- Aggressive or Salty Solutions
- Unsuitable for Oils & Other Low or Non-Conductive Medias

Areas of Application

Flow Monitoring, Flow Measuring, Batching and Totalizing for:

- Machine Building
- Chemical Industry
- Paper Industry
- Automobile Industry
- Cement Industry
- Laboratories

Technical Data

- Range:** See Table
- Accuracy:** ±2.0 % of f. s.
- Repeat Accuracy:** ±1.0 % of f. s. (f. s. = full scale)
- Measurement Process:** Electromagnetic
- Electrical Conductivity:** Min. 30 µS /cm (MIK-..U0.. & MIK-..U1.., Min. 200 µS /cm)
- Mounting Position:** Universal, Flow in Direction of the Arrow
- Inlet/Outlet Straight Run:** 3 x PD / 2 x PD (Pipe Diameters)
- Media Temperature:** -4 ... 176 °F (max. 140 °F with PVC-connection Set)
- Ambient Temperature:** 14 ... 140 °F
- Max. Pressure:** 145 psi
- Max. Pressure Loss:** Max. 3.7 psi at f.s.
- Max. Media Viscosity:** Max. 20 cSt for ranges: U0...U8
Max. 70 cSt for ranges: UA...UH

Wetted Parts

- Sensor Housing:** PPS or PVDF, Fiberglass-reinforced
- Native Connection:** G 1/2 to G 2-3/4
- Optional Connection Set:** NPT, PVC-glue Connections, Hose Barb, or Butt Weld Connections 316L Stainless Steel
- Electrodes:** 316L Stainless Steel, Hastelloy C4, or Tantalum
- Seal:** NBR, FKM, or FFKM
- Response Time t₉₀:** ca. 1 s
- Protection:** IP 65

Connection/Ranges

Native Connection	Inside Diameter	Flow Velocity at f.s.	Range
G ½ male	5 mm	approx. 0.45 m/s	0.18... 7.8 gph
		approx. 0.9 m/s	0.78... 15.6 gph
		approx. 2.7 m/s	2.4... 48.0 gph
G ¾ male	10 mm	approx. 2.2 m/s	0.13 ... 2.6 gpm
		approx. 3.5 m/s	0.2 ... 4.0 gpm
G 1 male	15 mm	approx. 3.0 m/s	0.4 ... 8.0 gpm
		approx. 4.7 m/s	0.65 ... 13 gpm
G 1 ½ male	20 mm	approx. 3.3 m/s	0.8... 16 gpm
		approx. 5.3 m/s	1.3 ... 26 gpm
G 2 male	32 mm	approx. 3.3 m/s	2.0 ... 40 gpm
		approx. 5.9 m/s	4.0 ... 75 gpm
G 2 ¾ male	54 mm	approx. 3.6 m/s	6.5 ... 130 gpm
		approx. 5.1 m/s	9.0 ... 180 gpm

**MIK-...F300, MIK-...F390**

Pulse Output:	PNP, Open Collector, max. 200 mA 500 Hz at f. s. (...F300) 50...1000 Hz at f. s. (...F390) Factory Set as per Customer Request
Power Supply:	24 V _{DC} ±20 %
Power Consumption:	60 mA
Electrical Connection:	Plug M 12 x 1

MIK-...S300, MIK-...S30D

Display:	Duo-LED for Switch Status
Switching Output:	Relay SPDT, Max. 1A/30V _{DC} or Active 24 V _{DC} , N/C / N/O
Switch Point:	10 ...100% of f. s. in 10%-Steps User Configured via Rotary Switch
Power Supply:	24 V _{DC} ±20 %
Power Consumption:	80 mA
Electrical Connection:	Plug M 12 x 1, 5-pin

MIK-...L343

Output:	4-20 mA, 3-wire
Max. Load:	500 Ω
Power Supply:	24 V _{DC} ±20%
Power Consumption:	80 mA
Electrical Connection:	Plug M 12 x 1

MIK-...L443 (Optional Use with AUF-3000)

Output:	4-20 mA, 3-wire
Max. Load:	500 Ω
Power Supply:	24 V _{DC} ±20%
Power Consumption:	80 mA
Electrical Connection:	Plug DIN 43650

MIK-...C3T0 (Compact Electronics)

Supply Voltage:	19-30 V _{DC} , Max. Internal Power Consumption: 200 mA
Display:	TFT Display, 128x128 Pixels, 1.4" Display, Orientation Adjustable in 90° Increments
Display Repetition Rate:	0.5... 10 s, Adjustable
Pulse Output:	Push-Pull, Freely Scalable, Configurable for Partial and Accumulated Totalizer
Frequency Output:	Push-Pull, Fully Scalable, 2 kHz at Overflow 50... 1000 Hz at Full Scale, User Programmable
Alarm Output:	NPN, PNP, Push-Pull, Configurable Max. 30 V _{DC} , Max 200 mA, Short-Circuit Proof
Control Output:	Active Signal U _{high} Max. 30 V _{DC} , 0 < Low < 10 V _{DC} , 15 V _{DC} < High < V _s
Batching Function:	Batching Output OUT2: Push-Pull, High Active Control Input OUT1: START/STOP 0.5s < t _{high} < 4s RESET t _{high} > 5s
Shock Resistance	DIN EN 60068-2-27:2010: 20 g (11 ms)
Vibration Resistance	DIN EN 60068-2-6:2008: 5 g (10... 2000 Hz)
Environmental Testing	DIN EN 60068-2-30:2006: Severity Level b
Temperature Measurement (C3T0)	
Sensor:	Digital
Accuracy:	≤ +2°C (Flow > 0.2 m/s)
Measuring Range:	Temperature Range of Medium
Response Time Temperature t₉₀ (Signal Output):	< 20 s
IO-Link Specification	
Manufacturer ID:	1105 (Decimal), 0 x 0451 (Hex)
Manufacturer Name:	Kobold Messring GmbH
IO-Link Specification:	V1.1
Bitrate:	COM3
Minimal Cycle Time:	1.1 ms
SIO-Mode:	Yes (OUT1 in Configuration IO-Link)
Block Parameterisation:	Yes
Operational Readiness:	10 s
Max. Cable Length:	65.5 ft (20 m)

Electrical Connections

MIK-...S300

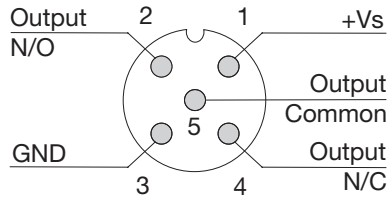

MIK-...S30D

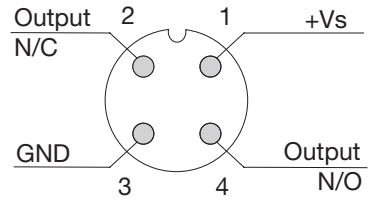

MIK-...L343, MIK-...F3x0

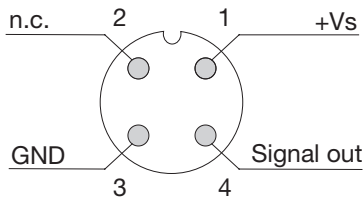

MIK-...L443

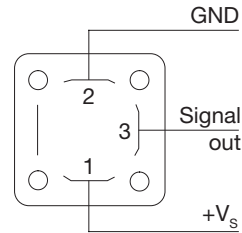

MIK-...C3T0

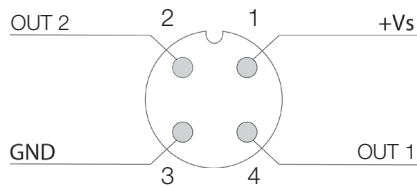

Configuration of Outputs (C3T0)

Output 1 (OUT1, PIN 4)	Output 2 (OUT2, PIN2)
Analog Output 0-10 V _{DC}	Analog Output 0-10 V _{DC}
Analog Output 4-20 mA	Analog Output 4-20 mA
Switching Output NPN/PNP/PP	Switching Output NPN/PNP/PP
Pulse Output PP	Pulse Output PP
Frequency Output PP	Frequency Output PP
Communication Mode KofiCom	
Communication Mode IO-Link	
Control Input	
Control Input Start/Stop/Reset Batching Function	Batching Function Switch/PP

Compact Magneto-Inductive Flowmeter Model MIK



Order Details (Example: **MIK-5NA U5 A F300**)

Model	Measuring Range, Native Process Connection	Optional Fitting Set	Output/Electronics
MIK-5NA.. = PPS-Housing, NBR-Seal, Stainless Steel Electrode	..U0.. = 0.18...7.8 GPH, G ½ ..U1.. = 0.78...15.6 GPH, G ½ ..U2.. = 2.4...48.0 GPH, G ½	..A.. = Without ¹⁾ ..N.. = PVC, 1/4" NPT Female ..P.. = PVC, 1/2" Hose Barb	Frequency Output ..F300 = M12-plug, 500 Hz ..F390 = M12-plug, 50...1000 Hz ²⁾ Switching Output ..S300 = Relay, M12-plug ..S30D = Active 24 V _{DC} , M12-plug Analog Output ..L343 = M12-plug, 4 - 20 mA ..L443 = DIN-plug, 4 - 20 mA Compact Electronic ..C3T0 = Compact TFT Display 2x Configurable Outputs (Current/Voltage/Pulse/ Frequency/Alarm) M12x1 Electrical Connection
	..U4.. = 0.13...2.6 GPM, G ¾ ..U5.. = 0.2...4.0 GPM, G ¾	..A.. = Without ¹⁾ ..M.. = PVC, 3/8" PVC Glue Socket ..N.. = PVC, 3/8" NPT Female ..P.. = PVC, 3/4" Hose Barb ..R.. = Polypropylene, 3/8" NPT Female	
MIK-5VA.. = PPS-Housing, FKM-Seal, Stainless Steel Electrode	..U7.. = 0.4...8.0 GPM, G 1 ..U8.. = 0.65...13 GPM, G 1	..A.. = Without ¹⁾ ..H.. = PVDF, 1/2" NPT Female ..M.. = PVC, 1/2" Glue Socket ..N.. = PVC, 1/2" NPT Female ..P.. = PVC, 1" Hose Barb ..R.. = Polypropylene, 1/2" NPT Female ..V.. = PVDF, Butt Weld 20mm O.D. Tube ..W.. = 316L SS, 1/2" NPT Female ..X.. = Brass, 1/2" NPT Female	
MIK-5NC.. = PPS-Housing, NBR-Seal, Hastelloy®- Electrode			
MIK-5VC.. = PPS-Housing, FKM-Seal, Hastelloy®- Electrode	..UA.. = 0.8...16 GPM, G 1½ ..UB.. = 1.3...26 GPM, G 1½	..A.. = Without ¹⁾ ..H.. = PVDF, 1" NPT Female ..M.. = PVC, 1" Glue Socket ..N.. = PVC, 1" NPT Female ..R.. = Polypropylene, 1" NPT Female ..V.. = PVDF, Butt Weld 32mm O.D. Tube	
MIK-6FC.. = PVDF-Housing, FFKM-Seal, Hastelloy®- Electrode	..UD.. = 2.0...40 GPM, G 2 ..UE.. = 4.0...75 GPM, G 2	..A.. = Without ¹⁾ ..H.. = PVDF, 1-1/4" NPT Female ..M.. = PVC, 1-1/4" Glue Socket ..N.. = PVC, 1-1/4" NPT Female ..R.. = Polypropylene, 1-1/4" NPT Female	
MIK-6FT.. = PVDF-Housing, FFKM-Seal, Tantalum- Electrode	..UG ⁴⁾ .. = 6.5...130 GPM, G 2 ¾ ..UH ⁴⁾ .. = 9.0...180 GPM, G 2 ¾	..A.. = Without ¹⁾ ..H.. = PVDF, 2" NPT Female ..M.. = PVC, 2" Glue Socket ..N.. = PVC, 2" NPT Female ..R.. = Polypropylene, 2" NPT Female	
Accessories: P/N 807.037 = 4-pin Micro-DC connector with 6-foot cable for output types F300, F390, L343, S30D, & C3T0 P/N 807.007 = 5-pin Micro-DC connector with 6-foot cable for output type S300			

¹⁾ Incl. frontal gaskets (2 pc. O-rings)
²⁾ Please specify frequency at full scale in clear text when ordering
³⁾ Please specify cable length in clear text
⁴⁾ Not for MIK-5NC/-5VC

Sensor Weight (Total Weight = Sensor + Electronics)

Model	PPS	PVDF
MIK-...U0/U1/U2 (½")	approx. 0.40 lb	approx. 0.43 lb
MIK-...U4/U5 (¾")	approx. 0.42 lb	approx. 0.50 lb
MIK-...U7/U8 (1")	approx. 0.60 lb	approx. 0.72 lb
MIK-...UA/UB (1 ½")	approx. 0.90 lb	approx. 1.10 lb
MIK-...UD/UE (2")	approx. 1.24 lb	approx. 1.35 lb
MIK-...UG/UH (2 ¾")	approx. 2.65 lb	approx. 3.02 lb

Electronics Weight (Total Weight = Sensor + Electronics)

Model	Weight
MIK-...F3x0 MIK-...S30x MIK-...Lxx3	approx. 0.18 lb
MIK-...C3T0	approx. 0.67 lb

No responsibility taken for errors;
 subject to change without prior notice.

www.koboldusa.com

* Total Weight = Sensor Weight + Electronics Weight

Dimensions

Model	G	L1	L2	L3	L4	L5	L6	H1	H2
MIK-xxxU0A MIK-xxxU1A MIK-xxxU2A	G 1/2	118	90	14	46	58	36	43	28
MIK-xxxU4A MIK-xxxU5A	G 3/4	122	90	16	46	58	36	43	28
MIK-xxxU7A MIK-xxxU8A	G 1	126	90	18	46	58	36	49,5	29,5
MIK-xxxUAA MIK-xxxUBA	G1 1/2	134	90	22	68	80	36	66	31,5
MIK-xxxUDA MIK-xxxUEA	G 2	138	90	24	68	80	36	72	36
MIK-xxxUGA MIK-xxxUHA	G 2 3/4	202	150	26	96	110	75	104	52

MIK-...F3x0, MIK-...S30x, MIK-...L343

MIK-...L443

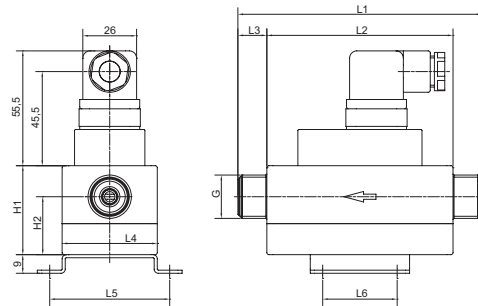
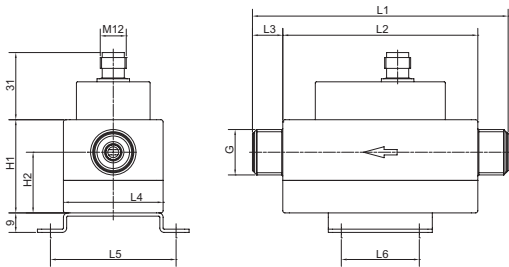

MIK-...C3T0

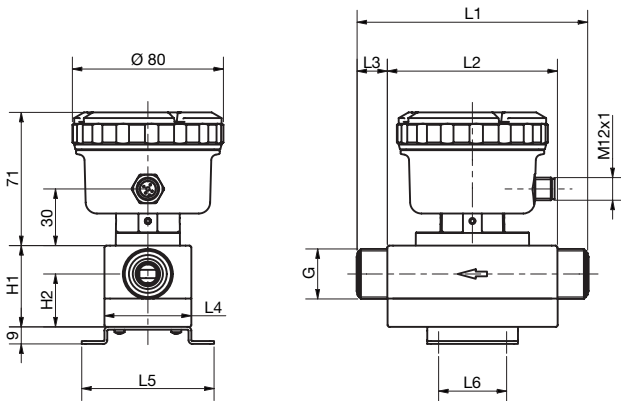

Dimensions Fitting Set ..H, M, N, R, W, X.. Connection

Reference table 7.1...table 7.5

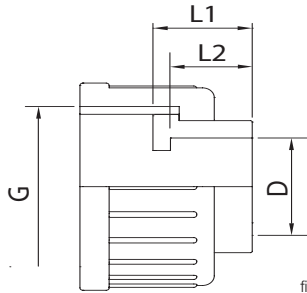

fig. 7.1

Dimensions Fitting Set ..N.. PVC- 1/4" NPT Connection

Reference table 7.1 G 1/2 only

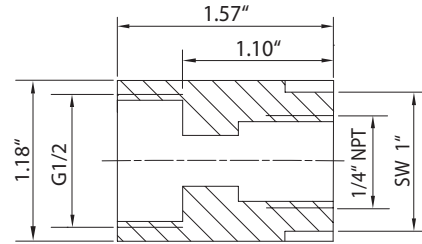

fig. 7.2

Dimensions Fitting Set ..N.. PVC-NPT Connection

G	L1	L2	D
G 1/2	Refer to figure 7.2		1/4" nom.
G 3/4	0.68"	0.52"	3/8" nom.
G 1	0.76"	0.68"	1/2" nom.
G 1 1/2	0.98"	0.87"	1" nom.
G 2	1.33"	0.98"	1-1/4" nom.
G 2 3/4	1.61"	0.98"	2" nom.

table 7.1

Dimensions Fitting Set ..H.. PVDF-NPT Connection

G	L1	L2	D
G 1	0.96"	0.79"	1/2" nom.
G 1 1/2	1.09"	0.83"	1" nom.
G 2	1.34"	0.91"	1-1/4" nom.
G 2 3/4	1.65"	1.22"	2" nom.

table 7.3

Dimensions Fitting Set ..R.. PP-NPT Connection

G	L1	L2	D
G 3/4	0.68"	0.55"	3/8" nom.
G 1	0.98"	0.79"	1/2" nom.
G 1 1/2	1.24"	0.94"	1" nom.
G 2	1.48"	1.18"	1-1/4" nom.
G 2 3/4	1.68"	1.22"	2" nom.

table 7.4

Dimensions Fitting Set ..M.. PVC-IPS Glue Connection

G	L1	L2	D
G 3/4	0.87"	0.79"	3/8" nom.
G 1	1.0"	0.89"	1/2" nom.
G 1 1/2	1.24"	1.14"	1" nom.
G 2	1.51"	1.39"	1-1/4" nom.
G 2 3/4	1.61"	1.5"	2" nom.

table 7.2

Dimensions Fitting Set ..W, X.. SS/Brass-NPT Connection

G	L1	L2	D
G 1	1.18"	0.63"	1/2" nom.

table 7.5

Dimensions Fitting Set ..V.. Butt Weld

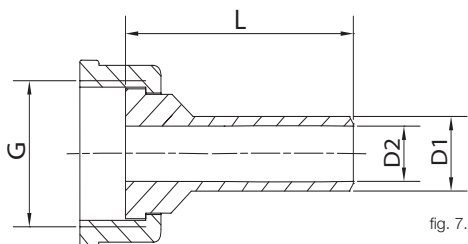

fig. 7.3

G	L	D1	D2
G 1	2.09"	0.79"	0.62"
G 1 1/2	2.32"	1.26"	1.05"

table 7.6

Dimensions Fitting Set ..P.. PVC-Hose Connection

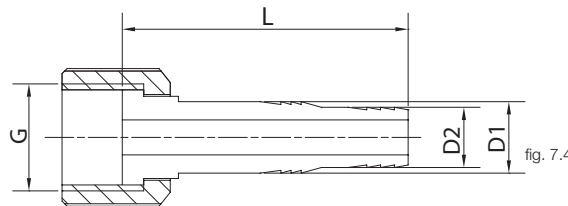

fig. 7.4

G	L	D1	D2
G 1/2	2.2"	0.55"	0.47"
G 3/4	2.36"	0.71"	0.63"
G 1	2.64"	0.87"	0.79"

table 7.7