

Quick Start Manual



Read the user's manual carefully before starting to use the unit.
Producer reserves the right to implement changes without prior notice.

Safety Information

- De-pressurize and vent system prior to installation or removal
- Confirm chemical compatibility before use
- **DO NOT** exceed maximum temperature or pressure specifications
- **ALWAYS** wear safety goggles or face-shield during installation and/or service
- **DO NOT** alter product construction



Warning | Caution | Danger

Indicates a potential hazard. Failure to follow all warnings may lead to equipment damage, injury, or death.



Personal Protective Equipment (PPE)

Always utilize the most appropriate PPE during installation and service of Truflo® products.



Note | Technical Notes

Highlights additional information or detailed procedure.



Pressurized System Warning

Sensor may be under pressure. Take caution to vent system prior to installation or removal. Failure to do so may result in equipment damage and/or serious injury.



Please ensure that the Instruments are not to be subject to water hammer or pressure spikes! Always Pressure Test System with H₂O Prior to Initial Start-Up

Before installation be certain the appropriate instrument has been selected considering operating pressure, full scale pressure, wetted material requirements, media compatibility, operating temperature, vibration, pulsation, desired accuracy and any other instrument component related to the service application including the potential need for protective attachments and/or special installation requirements. Failure to do so could result in equipment damage, failure and/or personal injury. Ensure only qualified personnel are permitted to install and maintain this instrument.



Pressurize System Warning

Sensor may be under pressure, take caution to vent system prior to installation or removal. Failure to do so may result in equipment damage and/or serious injury.



Please Ensure Full Pipe

TK Series can be installed in a horizontal or vertical direction. Please ensure enough length of straight pipe to avoid turbulence that can effect readings.



Min 10x Pipe Diameters Upstream 3x Pipe Diameters Downstream

A Bag Filter or Y Strainer Filtering Device upstream to Avoid the Paddle Wheel from being damaged by the solids or fibers - max 10% Particle Size - Not to Exceed .5mm Cross Section or Length. Please do not flush the pipe after the Flow Meter is installed with compressed air this may damage the ceramic shaft and will void warranty.



WARNING

Truflo® — TKW | TK3W Series (Blind) In-Line Paddle Wheel Flow Meter Sensor

Product Description

The TK Series in-line plastic paddle wheel flow meter has been engineered to provide long-term accurate flow measurement in tough industrial applications.

The paddle wheel assembly consists of an engineered Tefzel® paddle and micro-polished zirconium ceramic rotor pin and bushings. High performance Tefzel® and Zirconium materials have been selected due to their excellent chemical and wear resistant properties.

New ShearPro® Design

- ✓ Contoured Flow Profile
- ✓ Reduced Turbulence = Increased Longevity
- ✓ 78% Less Drag than Old Flat Paddle Design*

*Ref: NASA "Shape Effects on Drag"

Tefzel® Paddle Wheel

- ✓ Superior Chemical And Wear Resistance vs PVDF

Zirconium Ceramic Rotor | Bushings

- ✓ Up to 15x the Wear Resistance vs Regular Ceramic
- ✓ Integral Rotor Bushings Reduce Wear and Fatigue Stress

ShearPro® Through-Pin Design

- ✓ Eliminates Finger Spread
- ✓ No Lost Paddles
- ✓ Increased Temp. Rating
- ✓ 360° Housing Protects Rotor



ShearPro® vs. Competitor 'A'

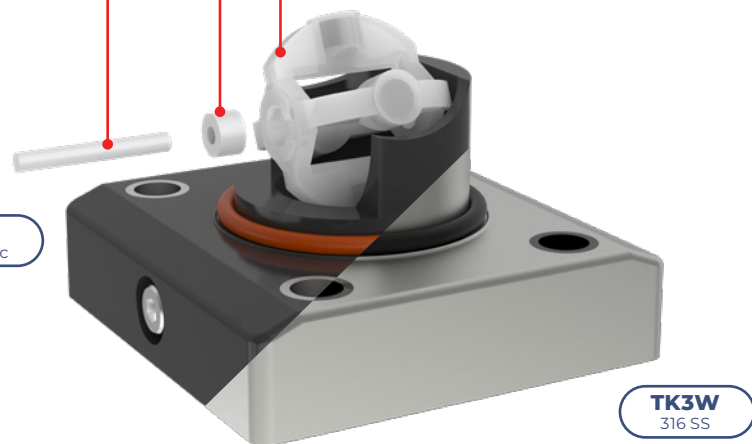
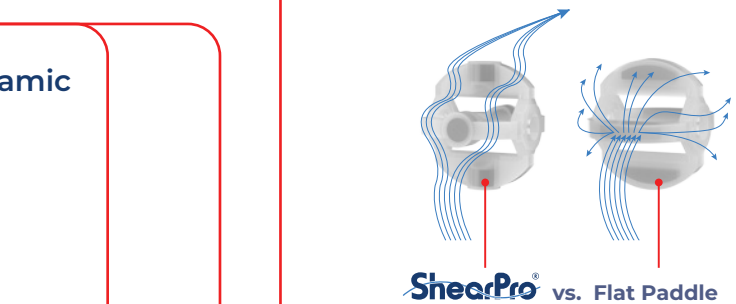
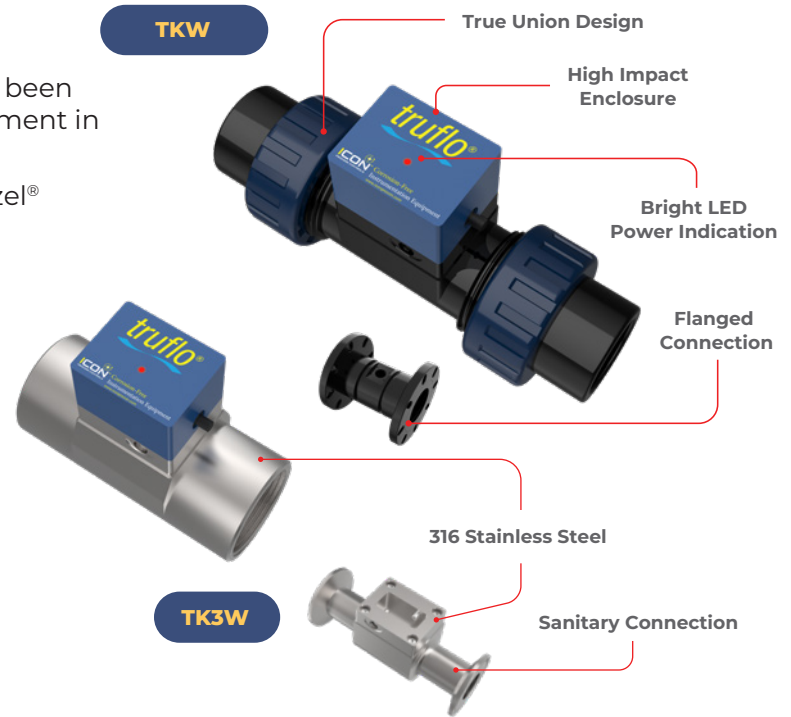

Truflo® — TKW | TK3W Series (Blind)

In-Line Paddle Wheel Flow Meter Sensor

Technical Specifications

General

| | | |
|--------------------|--|---------------|
| Operating Range | 0.3 to 33 ft/s | 0.1 to 10 m/s |
| Pipe Size Range | ¼ to 4" ** | DN08 to DN100 |
| Linearity | ±0.5% of F.S @ 25°C 77°F | |
| Repeatability | ±0.5% of F.S @ 25°C 77°F | |
| Fluid | Water or Chemical Liquid-Viscosity Range: .5-20 centistokes | |
| Flow Velocity | 10 m/s max. | |
| Low Cut | 0.3 m/s min. | |
| Operating Pressure | 150 Psi (10 Bar) @ Ambient Temp Non-Shock | |
| Range Ability | 10 : 1 | |
| Response Time | Real Time | |
| Flow Total Meter | Range = 0~999999 ; Unit = Gallon or Liter or Ton (KL) Selectable | |
| Repeatability | Range = 0.0~999.9 ; Unit = GPM or LPM or CMH Selectable | |
| Accuracy | ± 0.5% of F.S. @ 25°C | |

Wetted Materials

| | | |
|----------------------|---|--|
| Sensor Body | PVC (Dark) PP (Pigmented) PVDF (Natural) 316 SS | |
| O-Rings | FKM EPDM* FFKM* | |
| Rotor Pin Bushings | Zirconium Ceramic ZrO ₂ | |
| Paddle Rotor | ETFE Tefzel® | |

Electrical

| | | |
|----------------|----------------------------|------------------------|
| Frequency | 49 Hz per m/s nominal | 15 Hz per ft/s nominal |
| Supply Voltage | 9 to 30 VDC ±10% regulated | |
| Supply Current | <1.5 mA @ 3.3 to 6 VDC | <20 mA @ 6 to 24 VDC |

Max. Temperature/Pressure Rating – Standard and Integral Sensor | Non-Shock

| | | |
|--------|----------------------------------|----------------------------------|
| PVC | 180 Psi @ 68°F 40 Psi @ 140°F | 12.5 Bar @ 20°C 2.7 Bar @ 60°C |
| PP | 180 Psi @ 68°F 40 Psi @ 190°F | 12.5 Bar @ 20°C 2.7 Bar @ 88°C |
| PVDF | 200 Psi @ 68°F 40 Psi @ 240°F | 14 Bar @ 20°C 2.7 Bar @ 115°C |
| 316 SS | 200 Psi @ 180°F 40 Psi @ 300°F | 14 Bar @ 82°C 2.7 Bar @ 148°C |

Operating Temperature

| | | |
|--------|----------------|----------------|
| PVC | 32°F to 140°F | 0°C to 60°C |
| PP | -4°F to 190°F | -20°C to 88°C |
| PVDF | -40°F to 240°F | -40°C to 115°C |
| 316 SS | -40°F to 300°F | -40°C to 148°C |

Outputs

| |
|------------------------------|
| NPN Pulse Voltage 4-20mA |
|------------------------------|

Display

| |
|-----------------------|
| Blind LED Indicator |
|-----------------------|

Standards and Approvals

| |
|--------------------------------|
| UL CE FCC RoHS Compliant |
|--------------------------------|

See Temperature and Pressure Graphs for more information

*Optional
** ¼" - ¾" SS Only

Truflo® — TKW | TK3W Series (Blind) In-Line Paddle Wheel Flow Meter Sensor

Wiring Diagram

4-20mA or Voltage

| Wire Color | Description |
|------------|-------------|
| Brown | + VDC |
| Black | 4-20 mA |
| White | 4-20 mA |
| Blue | - VDC |

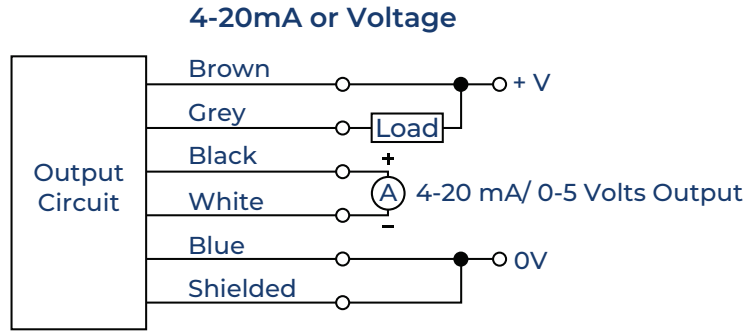

NPN Pulse Output

| Wire Color | Description |
|------------|-------------|
| Brown | + VDC |
| Black | Pulse |
| Blue | - VDC |

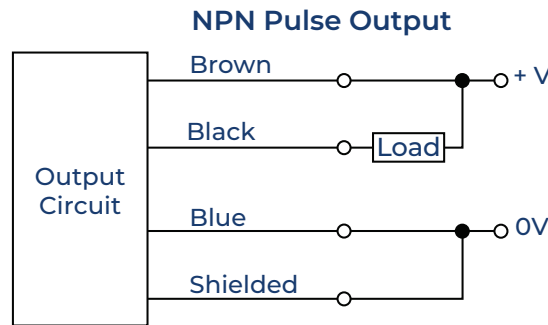

Temperature | Pressure Graphs | Non-Shock

Note: The Pressure/Temperature graphs are specifically for the Truflo® Flow Meter Sensors.

During system design the specifications of all components must be considered.

Min/Max Flow Rates

| Pipe Size (O.D.) | LPM GPM | | LPM GPM | |
|------------------|-------------|------|------------|------|
| | 0.3m/s min. | | 10m/s max. | |
| DN08 (¼") | 0.6 | 0.16 | 12 | 3 |
| DN10 (⅜") | 1.8 | 0.48 | 50 | 13 |
| DN15 (½") | 3.5 | 1.0 | 120 | 32 |
| DN20 (¾") | 5.0 | 1.5 | 170 | 45 |
| DN25 (1") | 9.0 | 2.5 | 300 | 79 |
| DN40 (1½") | 25.0 | 6.5 | 850 | 225 |
| DN50 (2") | 40.0 | 10.5 | 1350 | 357 |
| DN65 (2½") | 60.0 | 16.0 | 1850 | 357 |
| DN80 (3") | 90.0 | 24.0 | 2800 | 739 |
| DN100 (4") | 125.0 | 33.0 | 4350 | 1149 |

◀ SS Only

◀ SS Only

■ = PVC ■ = PP ■ = PVDF

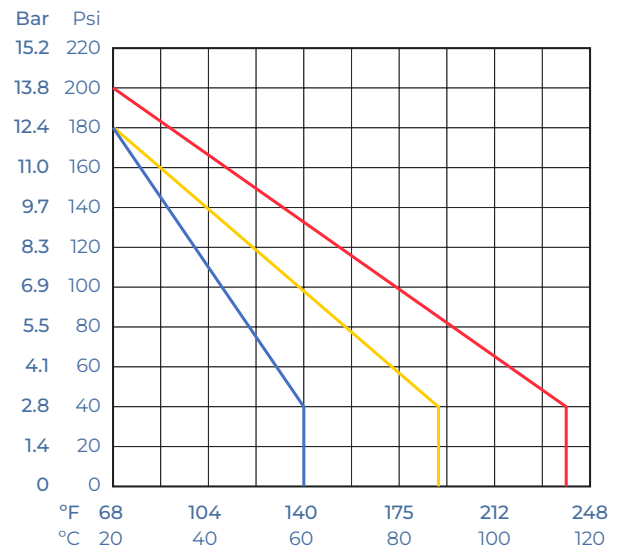

Truflo® — TKW | TK3W Series (Blind) In-Line Paddle Wheel Flow Meter Sensor

Exploded View

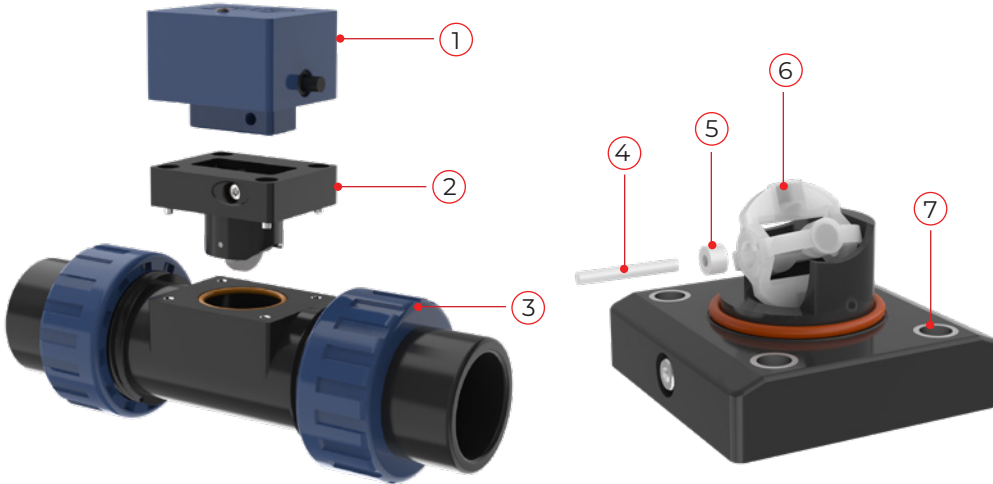

| | |
|---|------------------------|
| 1 | Flow Controller |
| 2 | Rotor Assembly |
| 3 | Body - PVC PP PVDF |
| 4 | Rotor Pin |
| 5 | Rotor Bushing |
| 6 | ShearPro® Paddle Wheel |
| 7 | Reinforced Inserts |

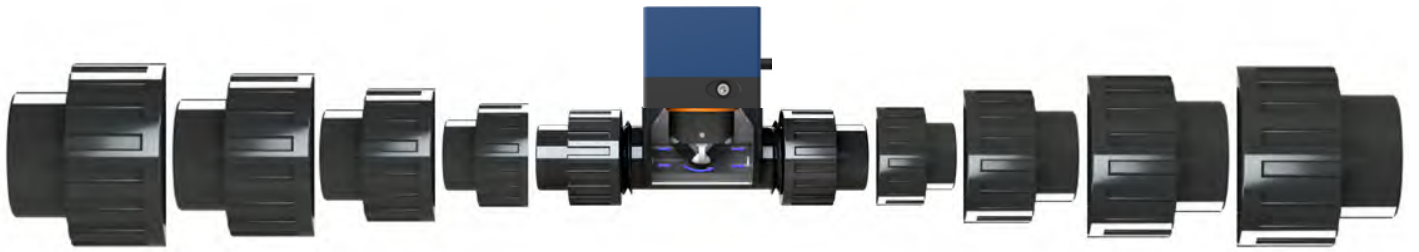

2" ← ½" Same Controller | Rotor Assembly for All Sizes

Dimensions

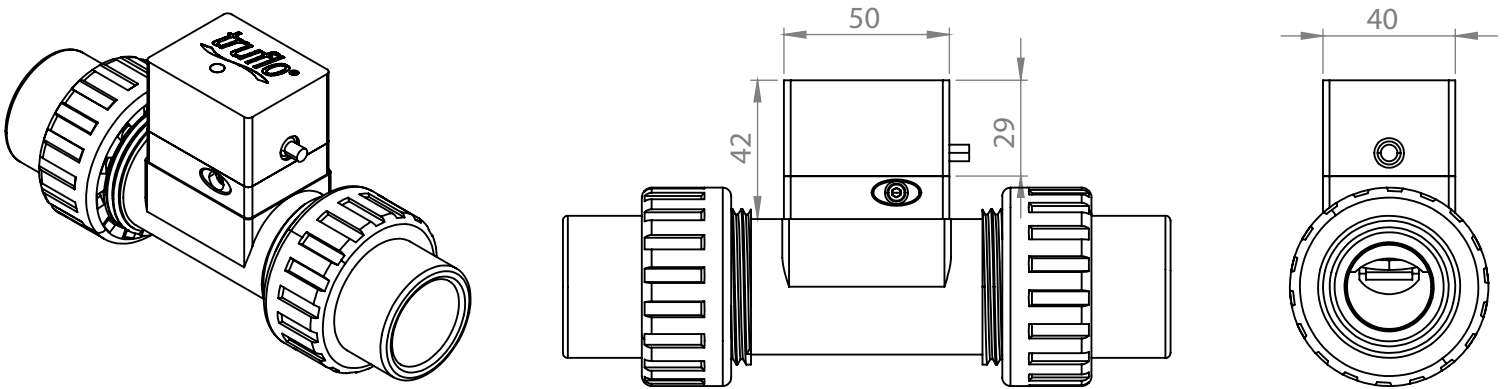

Truflo® — TKW | TK3W Series (Blind)

In-Line Paddle Wheel Flow Meter Sensor

K-Factors for TK Series (V1)

| Size | LPM | GPM |
|------|------|------|
| ¼" | 547 | 2079 |
| ⅜" | 300 | 1140 |
| ½" | 124 | 471 |
| ¾" | 72 | 274 |
| 1" | 54 | 171 |
| 1½" | 19 | 72 |
| 2" | 10.3 | 39 |
| 3" | 4.7 | 18 |
| 4" | 2.1 | 8 |

⚠ K-Factor is Pre-Programmed

K-Factors for TK Series (V2)

| Size | K-Factor |
|------|----------|
| ½" | 127.6 |
| ¾" | 81.8 |
| 1" | 55.1 |
| 1½" | 18.8 |
| 2" | 10.2 |
| 2½" | 6.0 |

Range of Transmitter

| Size | Range LPM GPM |
|------------|---------------------|
| DN8* ¼" | 0-6 LPM 0-1.6 GPM |
| DN10* ⅜" | 0-15 LPM 0-4 GPM |
| DN15 ½" | 0-30 LPM 0-8 GPM |
| DN20 ¾" | 0-60 LPM 0-16 GPM |
| DN25 1" | 0-90 LPM 0-24 GPM |

| Size | Range LPM GPM |
|-------------|------------------------|
| DN40 1 ½" | 0-200 LPM 0-53 GPM |
| DN50 2" | 0-330 LPM 0-87 GPM |
| DN80 3" | 0-750 LPM 0-198 GPM |
| DN100 4" | 0-1300 LPM 0-344 GPM |

* SS Only

Model Selection

| PVC | | |
|------|-----------------|-------------|
| Size | End Connections | Part Number |
| ½" | Sch 80 Soc | TKW-15-P |
| ¾" | Sch 80 Soc | TKW-20-P |
| 1" | Sch 80 Soc | TKW-25-P |
| 1 ½" | Sch 80 Soc | TKW-40-P |
| 2" | Sch 80 Soc | TKW-50-P |
| 3" | Flanged | TKW-80-P |
| 4" | Flanged | TKW-100-P |

| PP | | |
|------|-----------------|-------------|
| Size | End Connections | Part Number |
| ½" | NPT | TKW-15-PP |
| ¾" | NPT | TKW-20-PP |
| 1" | NPT | TKW-25-PP |
| 1 ½" | NPT | TKW-40-PP |
| 2" | NPT | TKW-50-PP |
| 3" | Flanged | TKW-80-PP |
| 4" | Flanged | TKW-100-PP |

| PVDF | | |
|------|-----------------|-------------|
| Size | End Connections | Part Number |
| ½" | NPT | TKW-15-PF |
| ¾" | NPT | TKW-20-PF |
| 1" | NPT | TKW-25-PF |
| 1 ½" | NPT | TKW-40-PF |
| 2" | NPT | TKW-50-PF |

Add 1st Suffix (end connection):

- T ▶ NPT End Connectors (on PVC)
- B ▶ Butt Fused End Connections for PP or PVDF
- F ▶ Flange ANSI 150lb - Consult Factory

Add 2nd Suffix (seals):

- FKM (std, no suffix required)
- E ▶ EPDM Seals
- K ▶ FFKM | Kalrez® Seals

Add 3rd Suffix (optional output):

- A ▶ 4-20mA Output
- V ▶ 0-5 V Output
- PA ▶ 4-20mA + Pulse Output

Note: PVC Socket Ends (Std)
PP/PVDF NPT Ends (Std)

| 316 SS | | |
|--------|-----------------|-------------|
| Size | End Connections | Part Number |
| ¼" | NPT | TK3W-08-SS |
| ⅜" | NPT | TK3W-10-SS |
| ½" | NPT | TK3W-15-SS |
| ¾" | NPT | TK3W-20-SS |
| 1" | NPT | TK3W-25-SS |
| 1 ½" | NPT | TK3W-40-SS |
| 2" | NPT | TK3W-50-SS |
| 3" | NPT | TK3W-80-SS |
| 4" | NPT | TK3W-100-SS |

Add 1st Suffix (end connection):

- T ▶ NPT End Connectors
- SE ▶ Sanitary - Consult Factory for Pricing
- F ▶ Flange ANSI 150lb - Consult Factory

Add 2nd Suffix (seals):

- FKM (std, no suffix required)
- E ▶ EPDM Seals
- K ▶ FFKM | Kalrez® Seals

Add 3rd Suffix (optional output):

- A ▶ 4-20mA Output
- V ▶ 0-5 V Output
- PA ▶ 4-20mA + Pulse Output

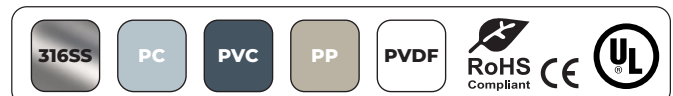

Installation Position

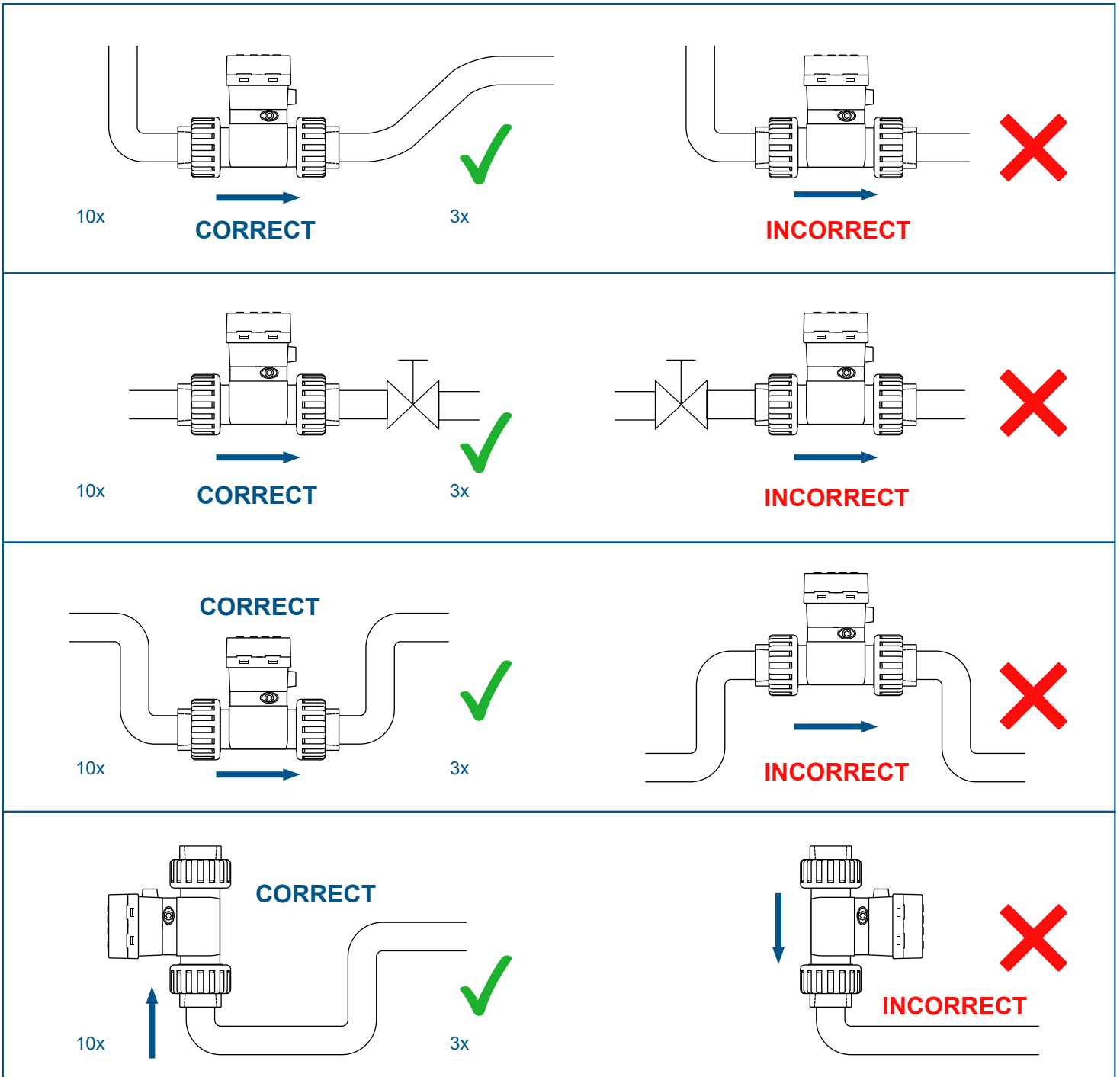

Please Ensure Full Pipe

TK Series can be installed in a horizontal or vertical direction. Please ensure enough length of straight pipe to avoid turbulence that can effect readings.

Note: Min 10x Pipe Diameters Upstream 3x Pipe Diameters Downstream.

A Plastic Basket Strainer, Bag Filter or Y Strainer Filtering Device upstream to Avoid the Paddle Wheel from being damaged by the solids or fibers - max 10% Particle Size - Not to Exceed .5mm Cross Section or Length. Please do not flush the pipe after the Flow Meter is installed with Compressed Air this may damage the ceramic shaft and will Void Warranty.

Warranty, Returns and Limitations

Warranty

Icon Process Controls Ltd warrants to the original purchaser of its products that such products will be free from defects in material and workmanship under normal use and service in accordance with instructions furnished by Icon Process Controls Ltd for a period of one year from the date of sale of such products. Icon Process Controls Ltd obligation under this warranty is solely and exclusively limited to the repair or replacement, at Icon Process Controls Ltd option, of the products or components, which Icon Process Controls Ltd examination determines to its satisfaction to be defective in material or workmanship within the warranty period. Icon Process Controls Ltd must be notified pursuant to the instructions below of any claim under this warranty within thirty (30) days of any claimed lack of conformity of the product. Any product repaired under this warranty will be warranted only for the remainder of the original warranty period. Any product provided as a replacement under this warranty will be warranted for the one year from the date of replacement.

Returns

Products cannot be returned to Icon Process Controls Ltd without prior authorization. To return a product that is thought to be defective, go to www.iconprocon.com, and submit a customer return (MRA) request form and follow the instructions therein. All warranty and non-warranty product returns to Icon Process Controls Ltd must be shipped prepaid and insured. Icon Process Controls Ltd will not be responsible for any products lost or damaged in shipment.

Limitations

This warranty does not apply to products which:

1. are beyond the warranty period or are products for which the original purchaser does not follow the warranty procedures outlined above;
2. have been subjected to electrical, mechanical or chemical damage due to improper, accidental or negligent use;
3. have been modified or altered;
4. anyone other than service personnel authorized by Icon Process Controls Ltd have attempted to repair;
5. have been involved in accidents or natural disasters; or
6. are damaged during return shipment to Icon Process Controls Ltd

Icon Process Controls Ltd reserves the right to unilaterally waive this warranty and dispose of any product returned to Icon Process Controls Ltd where:

1. there is evidence of a potentially hazardous material present with the product;
2. or the product has remained unclaimed at Icon Process Controls Ltd for more than 30 days after Icon Process Controls Ltd has dutifully requested disposition.

This warranty contains the sole express warranty made by Icon Process Controls Ltd in connection with its products. ALL IMPLIED WARRANTIES, INCLUDING WITHOUT LIMITATION, THE WARRANTIES OF MERCHANTABILITY AND FITNESS FOR A PARTICULAR PURPOSE, ARE EXPRESSLY DISCLAIMED. The remedies of repair or replacement as stated above are the exclusive remedies for the breach of this warranty. IN NO EVENT SHALL Icon Process Controls Ltd BE LIABLE FOR ANY INCIDENTAL OR CONSEQUENTIAL DAMAGES OF ANY KIND INCLUDING PERSONAL OR REAL PROPERTY OR FOR INJURY TO ANY PERSON. THIS WARRANTY CONSTITUTES THE FINAL, COMPLETE AND EXCLUSIVE STATEMENT OF WARRANTY TERMS AND NO PERSON IS AUTHORIZED TO MAKE ANY OTHER WARRANTIES OR REPRESENTATIONS ON BEHALF OF Icon Process Controls Ltd. This warranty will be interpreted pursuant to the laws of the province of Ontario, Canada.

If any portion of this warranty is held to be invalid or unenforceable for any reason, such finding will not invalidate any other provision of this warranty.

For additional product documentation and technical support visit:

www.iconprocon.com | e-mail: sales@iconprocon.com or support@iconprocon.com | Ph: 905.469.9283



Phone: 905.469.9283 • **Sales:** sales@iconprocon.com • **Support:** support@iconprocon.com